

HF800

**FIXED MOUNT
BARCODE READER**

REFERENCE MANUAL

Fixed Mount Barcode Reader

Table of Contents

Introduction	5
About This Manual	5
Model Description	5
Package Contents	7
Accessories	7
Human Machine Interface	10
Electrical Characteristics	11
Mechanical Dimensions	14
Optic Characteristics	16
Getting Started	18
Mounting and Positioning	18
Connections	18
Connecting with Ethernet	18
Connecting with RS232	18
Connecting with RS485	19
Installing DataMax® Configuration Program	19
DataMax® Distribution Contents	19
Hardware Requirements	20
Software Requirements	20
How to Install	20
DataMax® User Interface Overview	24
Device List Area	24
Control and Help Panel	25
Main Menu and Toolbar	25
Device Discovery	25
Discover under Ethernet	26
Discover under Serial port	27
Device Information Description	28
Imaging Settings & Statistics	28
Live View	29
Log View	29
Statistics	30
Image Setup	30
Aimer & Light	31
Auto-Train	32
Image Cropping	33
Image Save	33
Charts Panel	34
Configurations Loading/Storage	35
Restore to Default	37
Communication Interface Setup	38
Network Setup	38
Network Grouping (Master/Slave)	41
Serial Interface Setup	43
Operating Mode	45
Streaming Presentation Mode	45

Presentation Mode	45
External Trigger Mode.....	46
External Trigger Delay.....	46
Trigger through remote commands	47
OneShot Mode	47
Burst Mode	47
Continuous Mode	48
Internal Trigger Mode.....	48
Symbologies.....	49
Message Length Description.....	49
1-D symbologies	49
Enable/Disable all 1-D symbologies.....	49
Code 11	50
Code 128.....	50
Code 39.....	51
Interleaved 2 of 5.....	53
GS1-128	53
Codabar.....	54
Code 93.....	54
UPC-A	55
UPC-E	56
EAN-8.....	57
EAN-13.....	57
MSI	58
GS1 DataBar Omnidirectional	58
GS1 DataBar Limited	59
GS1 DataBar Expanded.....	59
Stacked Symbologies.....	60
Enable/Disable all Stacked symbologies.....	60
PDF417	60
MicroPDF	61
Codablock A	61
Codablock F	61
2-D Symbologies.....	62
Enable/Disable all 2-D symbologies.....	62
Aztec	62
Maxicode	63
QR Code	64
DataMatrix.....	64
HanXin.....	65
Decoder Configurations	66
General Settings	66
Reread Delay	66
Read TimeOut.....	66
Good Read Delay	66
Decode Timeout	67
DPM Support.....	67

Show No Read	67
Output Sequence	67
Output Sequence Overview	67
Output Sequence Configuration Panel	68
Input/output settings	70
Input Channel settings	70
Polarity and Debounce time	70
Output Channel settings	71
Data Editing and Formatting	72
Prefix/Suffix Overview	72
Prefix/Suffix Selections	72
Data Format Editor Introduction	74
Add a Data Format	74
Advance Mode (command Line)	76
Maintenance	77
Firmware upgrade	77
Trouble Shooting	78
Customer Support	80
Technical Assistance	80
Product Service and Repair	80
Limited Warranty	80
Appendix A	82

Introduction

About This Manual

This Reference Manual provides installation and programming instructions for the HF800 fixed mount barcode reader.

Product specifications, dimensions, warranty and customer support information are also included.

Suggest to configure the reader with DataMax[®] Configuration Tool to make the reader working properly.

Model Description

The model type of HF800 can be separated into horizontal model and vertical model. Each model type includes the version of HD, SR and ER to meet different DOF requirement.

HF800 barcode reader series are all listed in the below table:

SKU	Description
HF800HD-1-1H	KIT, BLACK, HD, ETHERNET, STANDARD CAMERA
HF800SR-1-1H	KIT, BLACK, SR, ETHERNET, STANDARD CAMERA
HF800ER-1-1H	KIT, BLACK, ER, ETHERNET, STANDARD CAMERA
HF800HD-1-1V	KIT, BLACK, HD, ETHERNET, VERTICAL CAMERA
HF800SR-1-1V	KIT, BLACK, SR, ETHERNET, VERTICAL CAMERA
HF800ER-1-1V	KIT, BLACK, ER, ETHERNET, VERTICAL CAMERA

1. Horizontal model

This horizontal model type is used for most use cases . This model provides a laser aimer which helps user to locate the central position of the decoding area.



- ① Lens
- ② Aiming System (Laser pattern)
- ③ Mounting Holes(4)
- ④ Internal Illuminator
- ⑤ Human Machine Interface
- ⑥ Power-Serial-I/O Cable
- ⑦ Ethernet Connector
- ⑧ Device label

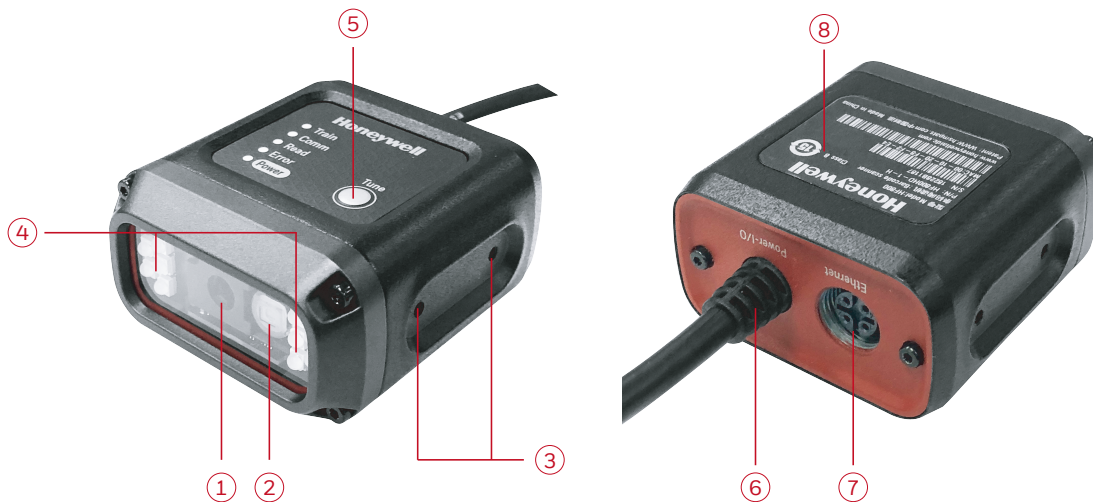

2. Vertical model

This vertical model type provide a kind of different way for mounting, which is usually can be used in narrow space in vertical direction. This model provides a Green LED aimer which helps user to locate the central position of the decoding area.





- ① Internal Mirror
- ② Lens
- ③ Internal Illuminator
- ④ Device label
- ⑤ Aiming System
- ⑥ Mounting Holes(4)
- ⑦ Human Machine Interface
- ⑧ Ethernet Connector
- ⑨ Power-Serial-I/O Cable

Package Contents

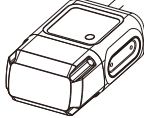
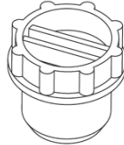
- 1、 HF800 Fixed Mount Barcode Reader
- 2、 Ethernet Pot Cover

Model	Name	Package content	Qty.	Appearance		
				Horizontal model		Vertical model
HF800	Fixed Mount Barcode Reader	Reader unit	1		OR	
		Ethernet pot cover (Assembled on reader)	1			

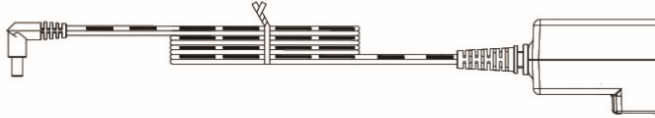
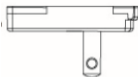
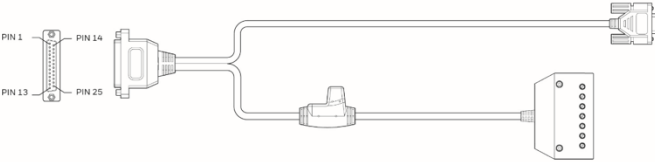
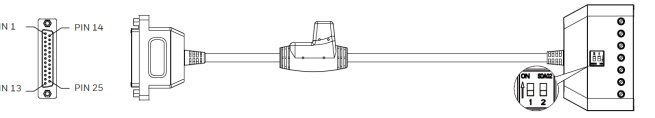
Accessories

Name	Part Number	Drawing
Adaptor	50129397-001	
Plug	50122315-001	
I/O+RS232 Cable	50142347-001	
I/O+RS485/422 Cable	50144214-001	
Ethernet Cable	50143315-001	
Mounting bracket kit	50145368-001	

Adaptor and Plug:

The input voltage of the adaptor is 100 - 240VAC, frequency is 50Hz - 60Hz, output voltage is 12.00+/-0.6VDC, maximum current is 1.25A. The adaptor should co-work with the plug, recommend to buy them both from Honeywell as an assembly.

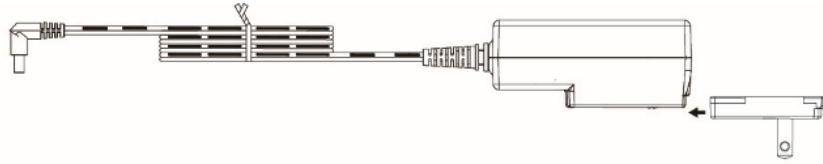

Note: The inside of the DC plug is negative, outside is positive. Recommend to use Honeywell adaptor only.

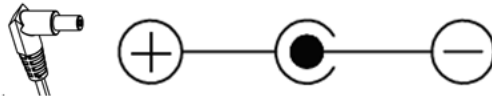

Terminal pinout for external I/O + RS232 cable:

Recommend to connect Shield to Ground for better EMI performance.

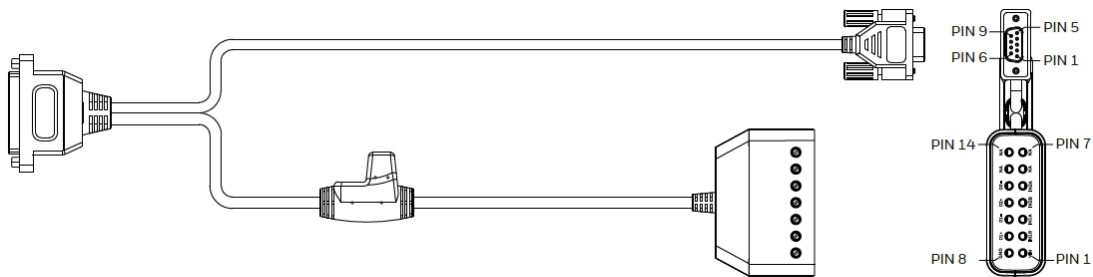

The Female DB9 connector description:

Pin NO.	Description
1	Shield
2	RS232_TX(output)
3	RS232_RX(input)
5	Ground
7	CTS(input)
8	RTS(output)
6,7,13,14 Reserved	

The 14 Pin connector description:

Pin NO.	Description	Pin NO.	Description	
1	Vin	Power supply	8 GND	Power supply ground
2	IN1B	External input 1B (Polarity insensitive)	9 O1+	Positive Output 1
3	IN1A	External input 1A (Polarity insensitive)	10 O1-	Negative Output 1
4	IN2B	External input 2B (Polarity insensitive)	11 O2+	Positive Output 2
5	IN2A	External input 2A (Polarity insensitive)	12 O2-	Negative Output 2
6,7,13,14 Reserved				

Terminal pinout for external I/O + RS485/422 cable:

There are 2 switches on the 485/422 cable, if slide on, HF800 485/422 will terminated with 120ohm, if slide off, there will be no termination resistor.

Note: For better signal quality, user should confirm that there are 2 120ohm termination resistors on data line (between data+ and data-), one near to host, the other one on the end.

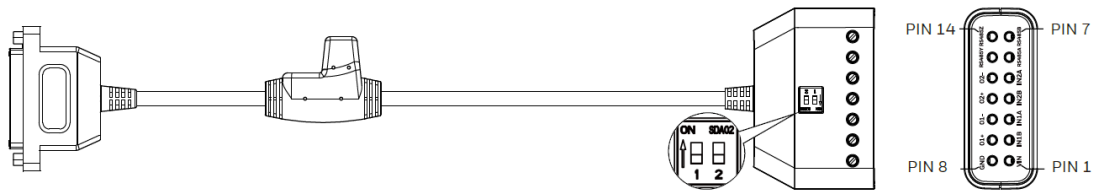

The 14 Pin connector description:

Pin NO.	Description	Pin NO.	Description
1 Vin	Power supply	8 GND	Power supply ground
2 IN1B	External input 1B (Polarity insensitive)	9 O1+	Positive Output 1
3 IN1A	External input 1A (Polarity insensitive)	10 O1-	Negative Output 1
4 IN2B	External input 2B (Polarity insensitive)	11 O2+	Positive Output 2
5 IN2A	External input 2A (Polarity insensitive)	12 O2-	Negative Output 2
RS485/422			
6 RS485_A	T/R+	13 RS485_Y	RX+
7 RS485_B	T/R-	14 RS485_Z	RX-

User could use ethier adaptor via DC jack or DC source via Vin pin in 14P connector to power HF800. When using adaptor, other accessories, such as beeper, external illumination or even another HF800 could draw current from the adaptor via Vin pin in the 14P connector, user need to confirm the total power consumption not exceed 15W.

Ethernet Cable



Ethernet Cable Pinout			
M12 Pin NO.	RJ45 Pin NO.	Name	Function
1	1	TX+	Transmitted data (+)
2	2	TX-	Transmitted data (-)
3	3	RX+	Received data (+)
4	6	RX-	Received data (-)

Mounting bracket

To mount the HF800, use the mounting bracket to obtain the most suitable position for the reader. This mounting bracket help user obtain rotation on the various axes of the reader.

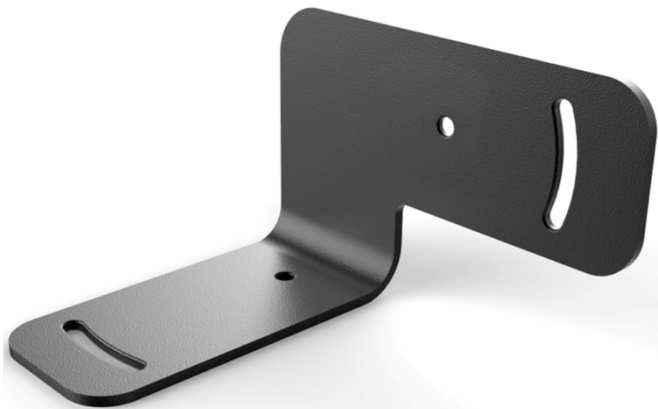

Human Machine Interface

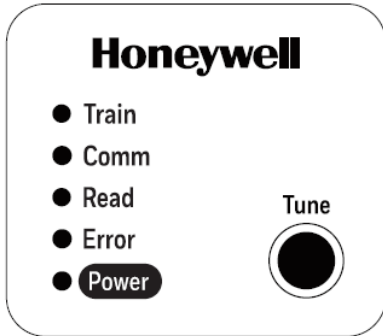

HF800 has 5 indicators to show the reader status and a tune button for easy configuration, detail function description as below.

Indicators description	
Train	Green/ Red LED. 1, When duration of pressing the Tune button in between 3s and 20s, the led will flick with green and red alternative in 100ms. Then release the button at this time, led will off. 2, When duration of pressing the Tune button for more than 20s, the led will flick with green and red alternative in 500ms. Then release the button at this time, led will off.
Comm	Yellow LED. Led blinks indicate the active data from the Ethernet line.
Read	Green. Green LED confirms successful reading.
Error	Red LED. If there is any error, red led on.
Power	White LED. Indicate the device is correctly powered.

Tune button description	
Tune	1, Keep press the button in between 3s and 20s, then release the button, reader will enter Auto-Train mode. The whole training process will last for several seconds. If trained success, the beeper will execute a good read tone sequence for three times. If trained failed, the beeper will also execute an error read tone sequence. 2, Keep press the button for more than 20s, then release the button, reader will enter the mode waiting for user to confirm the default operation. If press the button again in 10s, the reader will default all the configurations and the beeper will sound a menu read beep to notify the user. If doesn't press the button again beyond 10s, the reader will return to previous work states.

Electrical Characteristics

HF800 D-sub 25pin male connector

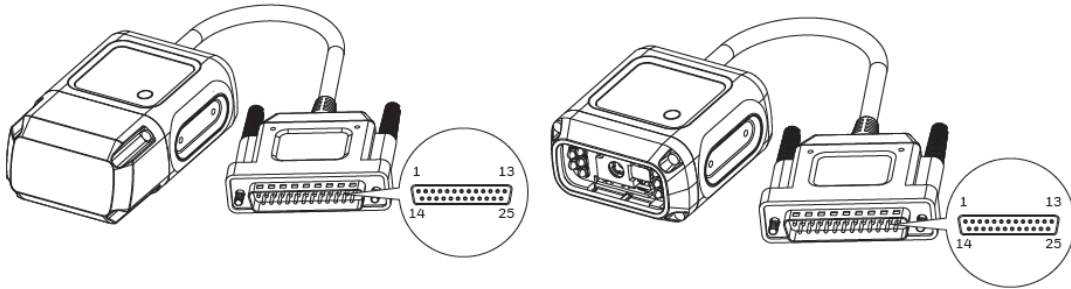

Power, COM and I/O Connector Pinout		
Pin number	Name	Function
9,13	Vin	Power supply input(10VDC-30VDC)
7,25	GND	Power supply ground
1	Shield	Chassis shield
2	RS232_TX	TXD(output)
3	RS232_RX	RXD(input)
4	RS232_RTS	RTS(output)
5	RS232_CTS	CTS(input)
6	IN2A	External Input channel 2 A
10	IN2B	External Input channel 2 B
18	IN1A	External Input channel 1 A
19	IN1B	External Input channel 1 B
8	O1+	Output 1 +
22	O1-	Output 1 -
11	O2+	Output 2 +
12	O2-	Output 2 -
14	RS485_Z	RX-(RS422 RX- only) (input)
15	RS485_Y	RX+(RS422 RX+ only) (input)
16	RS485_A	T/R+(RS485 data+ and RS422 TX+)
17	RS485_B	T/R-(RS485 data- and RS422 TX-)
20,21,23,24	Reserved	Reserved

Output

Two digital outputs (Output1, Output2) are available, with the protection of 2 optocouplers. The maximum V_{CE} of the optocoupler is 30VDC, maximum continuous current is 50mA. User should adjust the VDD and the load resistance to make sure the current is less than 50mA, and VDD is less than 30VDC. There are two Zener diodes paralleled with the Output Pin, and the Breakdown Voltage of the diode is 5.6V, therefore, if the external power supply which directly connected to the output pin is higher than 6V, the voltage will be clamped to 5.6V. User could use these 2 outputs to control beeper, external illumination LEDs.

Typical use case:

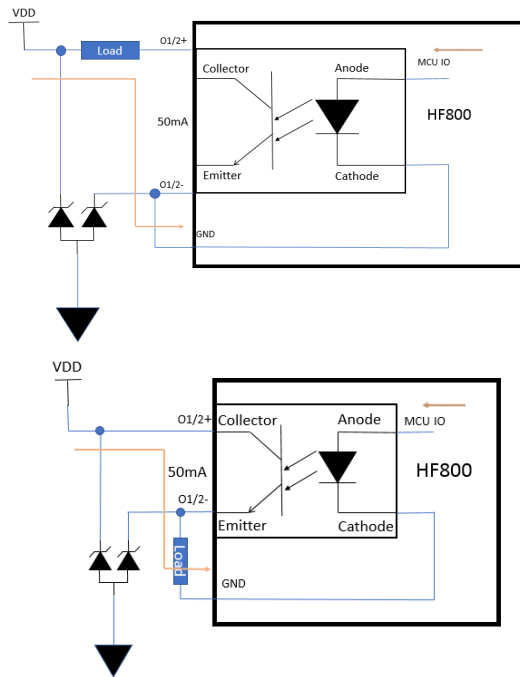

Input

Two digital inputs (Input1, Input2) are available, with the protection of 2 polarity insensitive optocouplers. Typical forward voltage of the optocoupler is 1.35V, maximum current is 50mA. User should adjust the VDD and the serial resistor to make sure the current is less than 50mA, VDD should be more than 1.35VDC and less than 30VDC. Maximum input frequency is 100KHz. User could connect external IR trigger, PLC to these 2 inputs.

Typical use case:

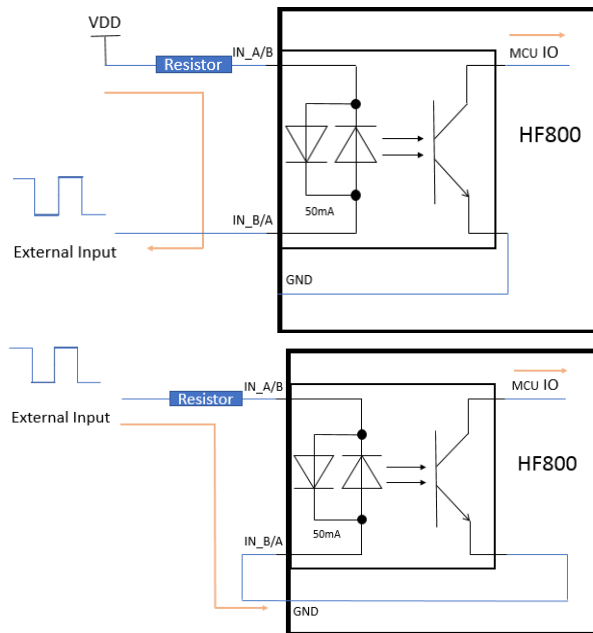

Typical NPN type IR connection to input2 layout as below, input1 as well, just need to replace IN2A with IN1A, replace IN2B with IN1B. A series resistor(1Kohm to 1.5Kohm) is recommended to be put between V+ and IN2A to limit the current.

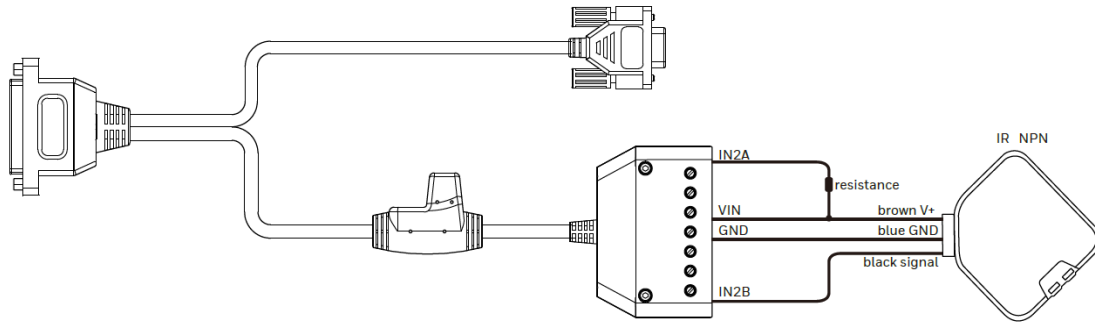

NPN type IR connected to external I/O+RS232 cable

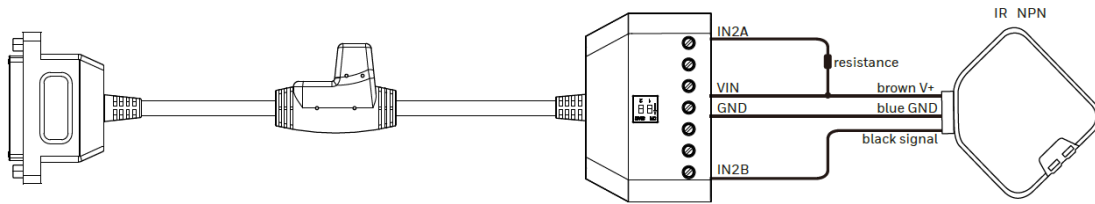

NPN type IR connected to external I/O+RS485/422 cable

Typical PNP type IR connection to input2 layout as below, input1 as well, just need to replace IN2A with IN1A, replace IN2B with IN1B. A series resistor(1Kohm to 1.5Kohm) is recommended to be put between signal and IN2A to limit the current.

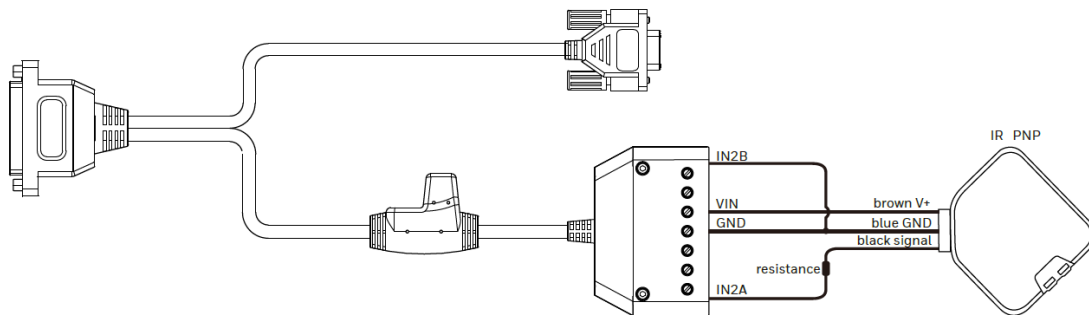

PNP type IR connected to external I/O+RS232 cable

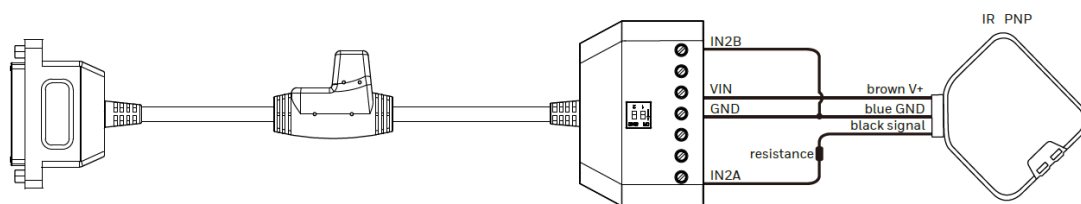

PNP type IR connected to external I/O+RS485/422 cable

RS232

HF800 support RS232 communication (hardware dataflow control configurable), default baud rate is 115200, could be configured to 4800, 9600, 19200, 38400.

RS485 and RS422

HF800 support both RS485 and RS422 communication, baud rate is 115200 fixed, user could only use one at a time (485 or 422). When using RS485, connect 485 data+ to RS485_A, connect 485 data- to RS485_B. RS485_Y and RS485_Z are for RS422 RX only.

Ethernet M12 Connector

HF800 support one 10/100M adaptable Ethernet, DHCP is enabled by default. If disabled, default IP is 192.168.1.110, net mask 255.255.255.0. M12 A coding connector for water proof, user should buy a M12 to RJ45 Ethernet transform cable from Honeywell in accessory list.

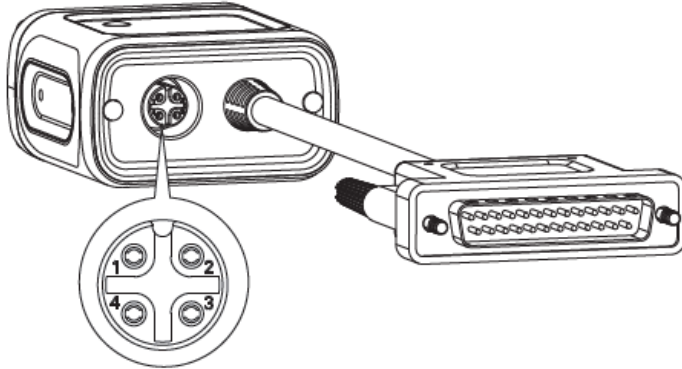

HF800 Ethernet Connector Pinout		
Pin number	Name	Function
1	TX+	Transmitted data (+)
2	TX-	Transmitted data (-)
3	RX+	Received data (+)
4	RX-	Received data (-)

Power requirements

HF800 reader supports a wide range of input power, from 10VDC to 30VDC, maximum power consumption is 5W (internal illumination).

Mechanical Dimensions

- Horizontal model: 54.5*52.5*29mm (L*W*H, Tolerance ±1mm)

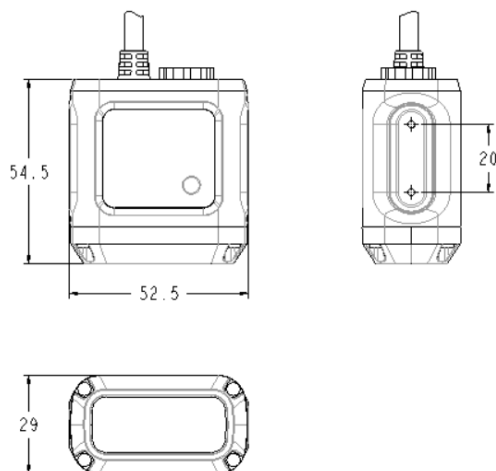

- Vertical model: 73.2*52.5*29mm (L*W*H, Tolerance ±1mm)

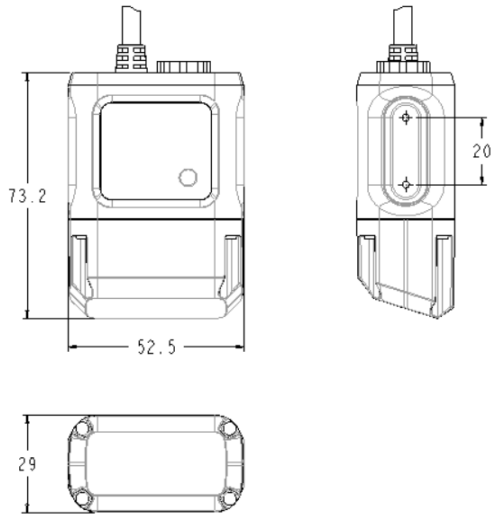

3. Mounting bracket overall dimensions

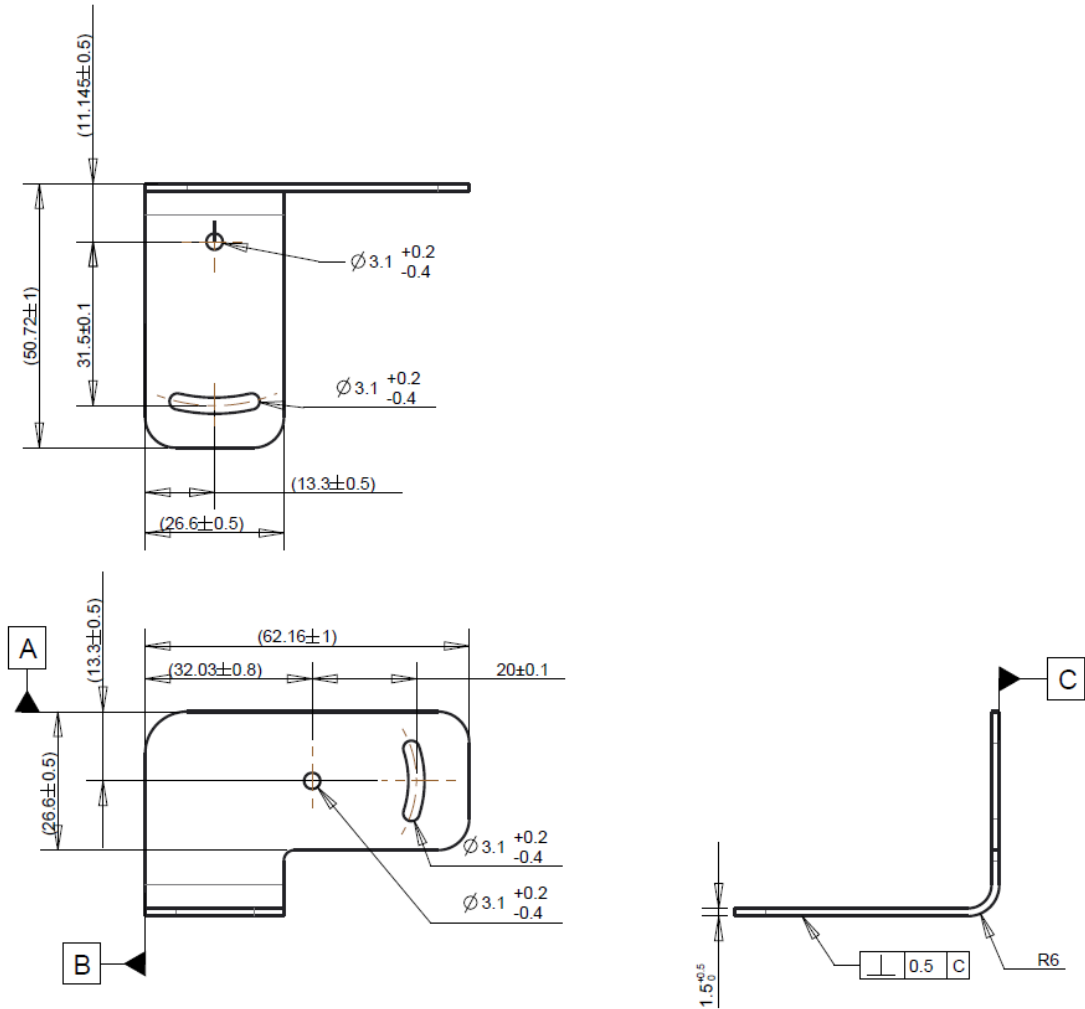

Optic Characteristics

DOF

Refer the data in the following table to adjust the installation distance for your application.

$$DOF = L_1 \sim L_2$$

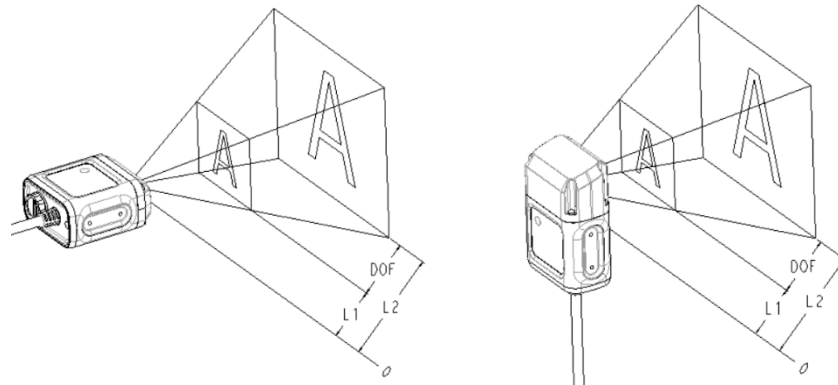

Depth of Field (DOF)		
Symbology	H	V
HD	Horizontal (L₁~L₂)	Vertical (L₁~L₂)
4mil Code 38	50~80 mm	25-55 mm
5mil Code 39	30~115 mm	25-90 mm
13 mil UPC	40~175 mm	25-150 mm
10 mil Data Matrix	22~ 128 mm	25-105 mm
20 mil Data Matrix	23~195 mm	25-170 mm
SR	Horizontal	Vertical
5mil Code 39	64~140 mm	39-115 mm
13 mil UPC	55~405 mm	30-380 mm
10 mil Data Matrix	62~190 mm	37-165 mm
20 mil Data Matrix	47~375 mm	25-350 mm
ER	Horizontal	Vertical
5mil Code 39	147~218 mm	122-193 mm
13 mil UPC	71~480 mm	46-455 mm
10 mil Data Matrix	135~250 mm	110-225 mm
20 mil Data Matrix	102~400 mm	77-375 mm

FOV Calculation

Use the data in the following table into formula to calculate the FOV for your application.

$$FOV_{range} = 2[(L_0 + L) * \tan(\theta/2)]$$

Example: HF800HD-1-1H @ 50mm

$$FOV_V = 2[(5 + 50) * \tan(32.2/2)] = 31.7mm$$

$$FOV_H = 2[(5 + 50) * \tan(41.4/2)] = 41.6mm$$

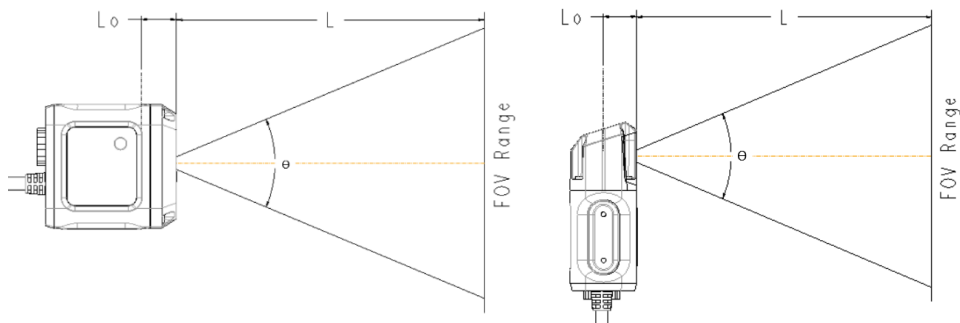

MODEL	L_0 (internal distance/mm)	θ_H (Horizontal angle)	θ_V (Vertical angle)
HF800HD-1-1H	5	41.4	32.2
HF800SR-1-1H	5	42.4	33
HF800ER-1-1H	5	31.6	24.4
HF800HD-1-1V	25	41.4	32.2
HF800SR-1-1V	25	42.4	33
HF800ER-1-1V	25	31.6	24.4

Getting Started

Mounting and Positioning

Using the HF800 mounting brackets you can obtain rotation on the various axes of the reader as shown in the diagrams below:

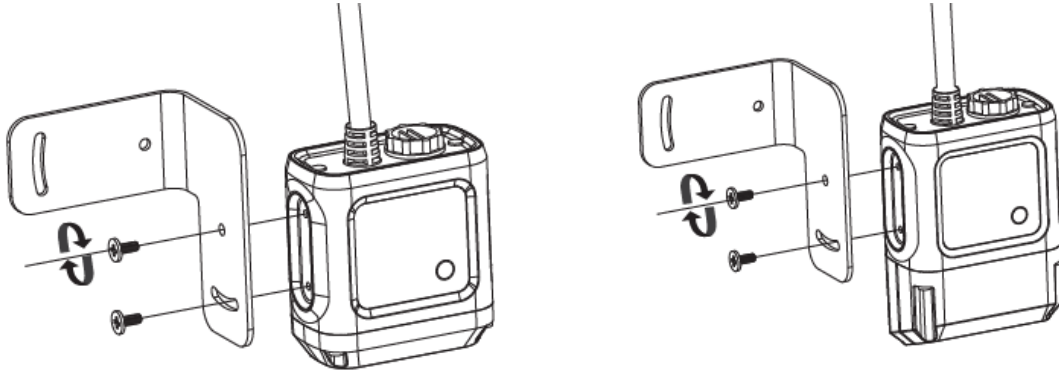

- Mounting screw size : M2.5

Connections

Connecting with Ethernet

To connect the system in an Ethernet point to point configuration, you need the hardware indicated as below.

In this layout, the data is transmitted to the Host from the HF800 on-board Ethernet interface by use the **Ethernet Cable** and powered by the **External 232/485 Cable**.

Note: if the device is not powered by the customer device, a **power adaptor** is need in this case.

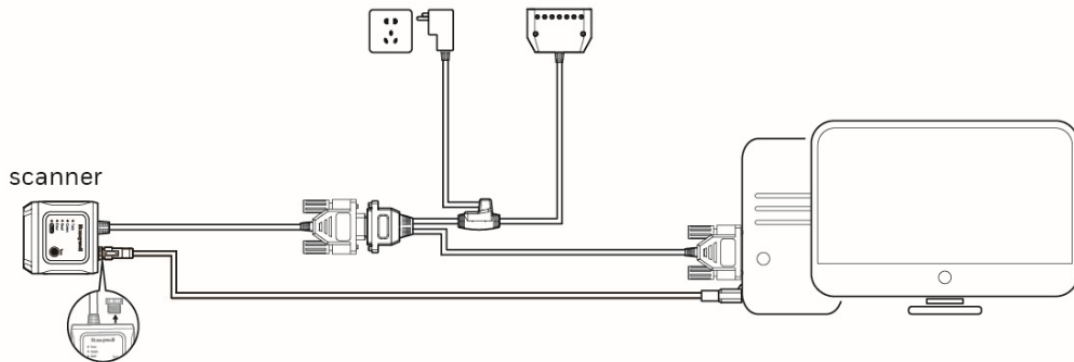

Connecting with RS232

To connect the system in a serial point to point configuration, you need the hardware indicated as below.

In this layout, the data is transmitted to the Host from the HF800 RS232 interface.

Note: the IO connector is combined with the RS232 interface, and if the device is not powered by the customer device, a **power adaptor** is need in this case.

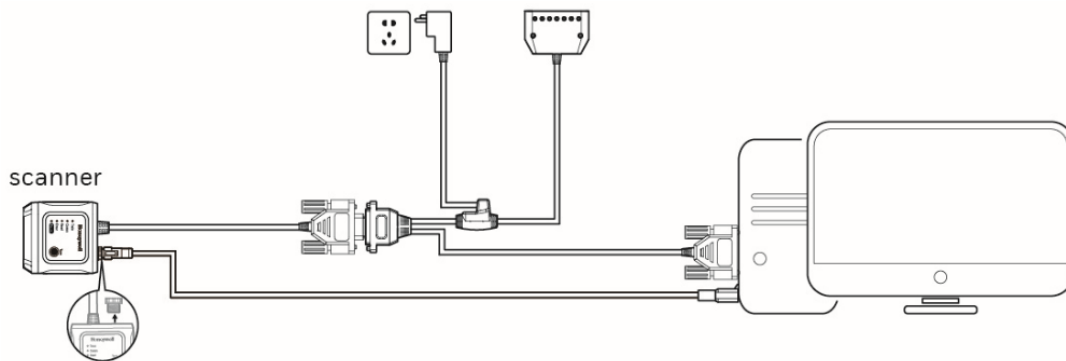

Connecting with RS485

To connect the system in a serial point to point configuration, you need the hardware indicated as below. In this layout, the data is transmitted to the Host from the HF800 RS485/422 interface.

Note: the IO connector is combined with the RS485/422 interface, and if the device is not powered by the customer device, a **power adaptor** is need in this case.

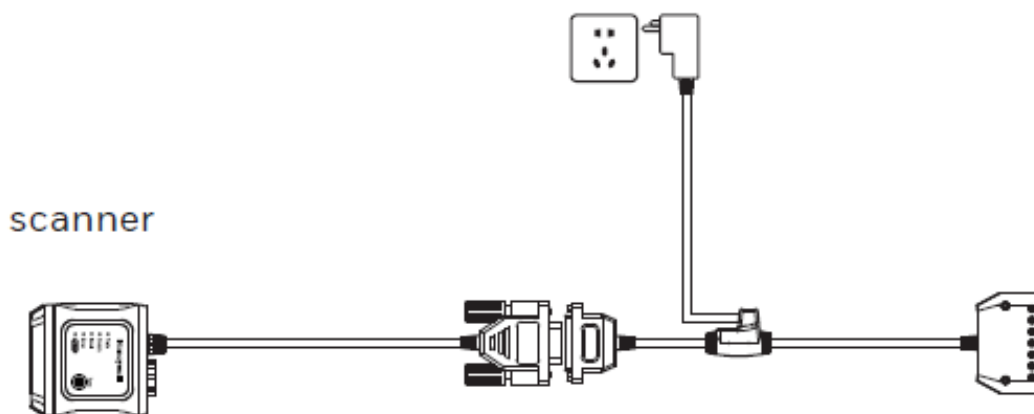

Installing DataMax[®] Configuration Program

DataMax[®] Distribution Contents

The DataMax[®] program distribution contains the following:



Hardware Requirements

Typical hardware requirements for a DataMax[®] Client PC are:

- a. 2.00GHz or faster microprocessor
- b. 1GB RAM
- c. 2GB hard disk for 64-bit machines; 1GB hard disk for 32-bit machines
- d. One 19" or larger monitor (optimized for 1280*1024 resolution)

Software Requirements

Windows Operating System (32 or 64-bit): Windows XP/7/8/10.

How to Install

1. Download the zip file on the PC. Extract the files that maintain the folder structure and run the setup file to access the installation pop-up. Click on the Install link to run the installation program and follow the installation process.
2. When the installation is complete, the DataMax[®] entry is created in the "Start" as well as a desktop shortcuts.
3. Double-click the desktop shortcut to run it.

Welcome page:

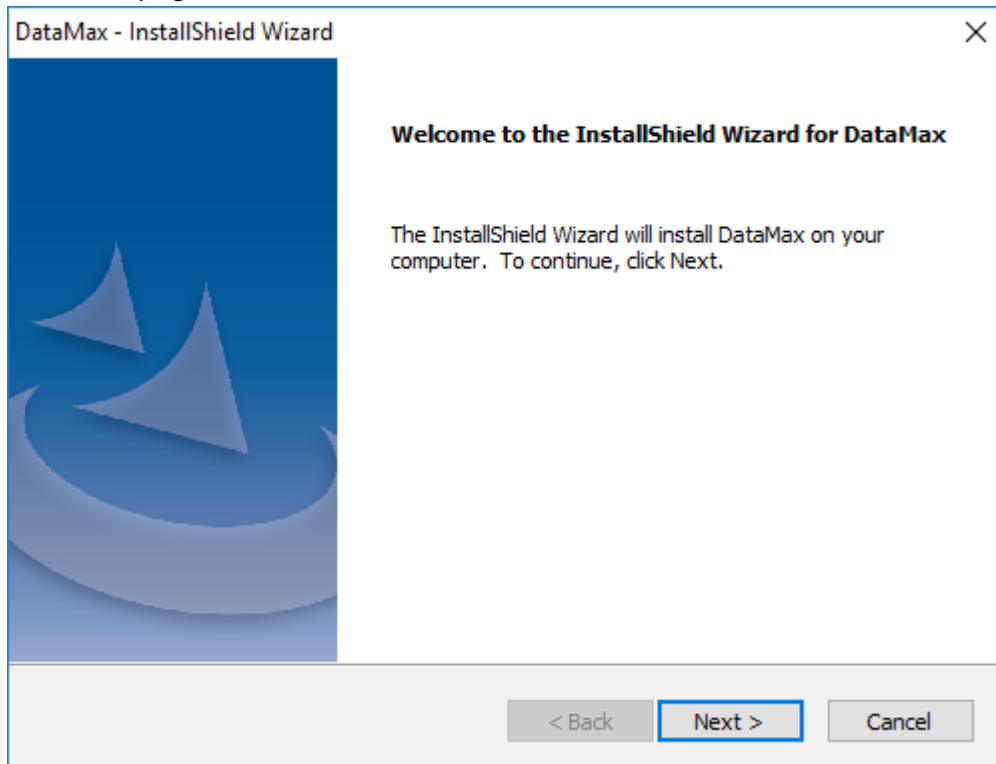

Privacy statement:

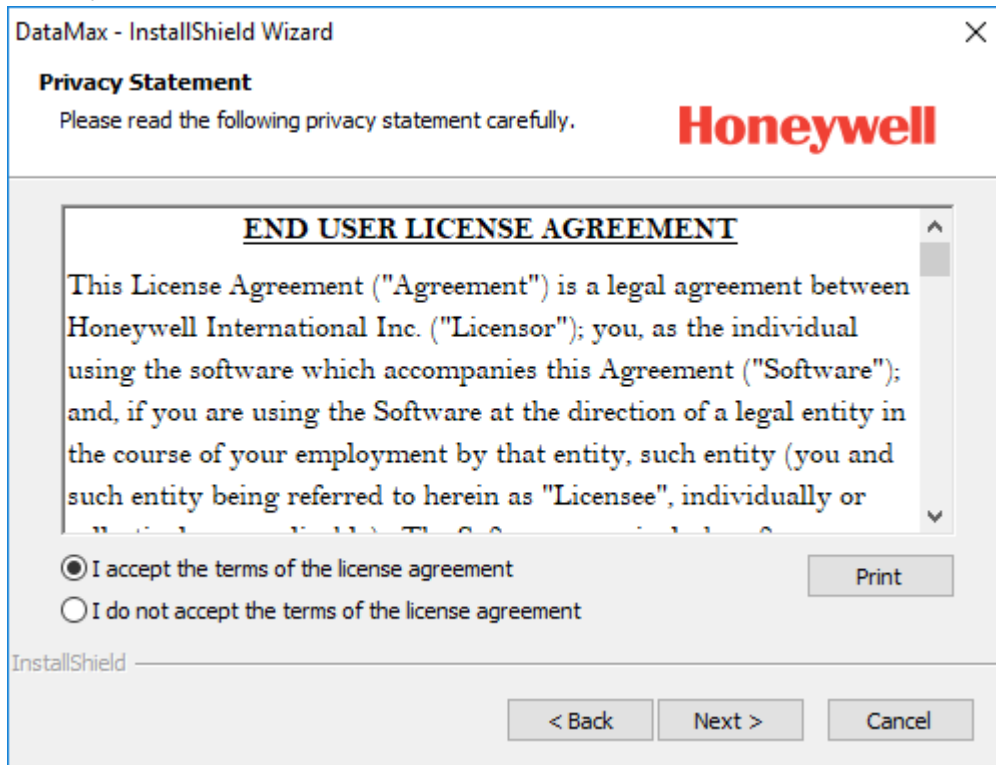

Privacy statement:

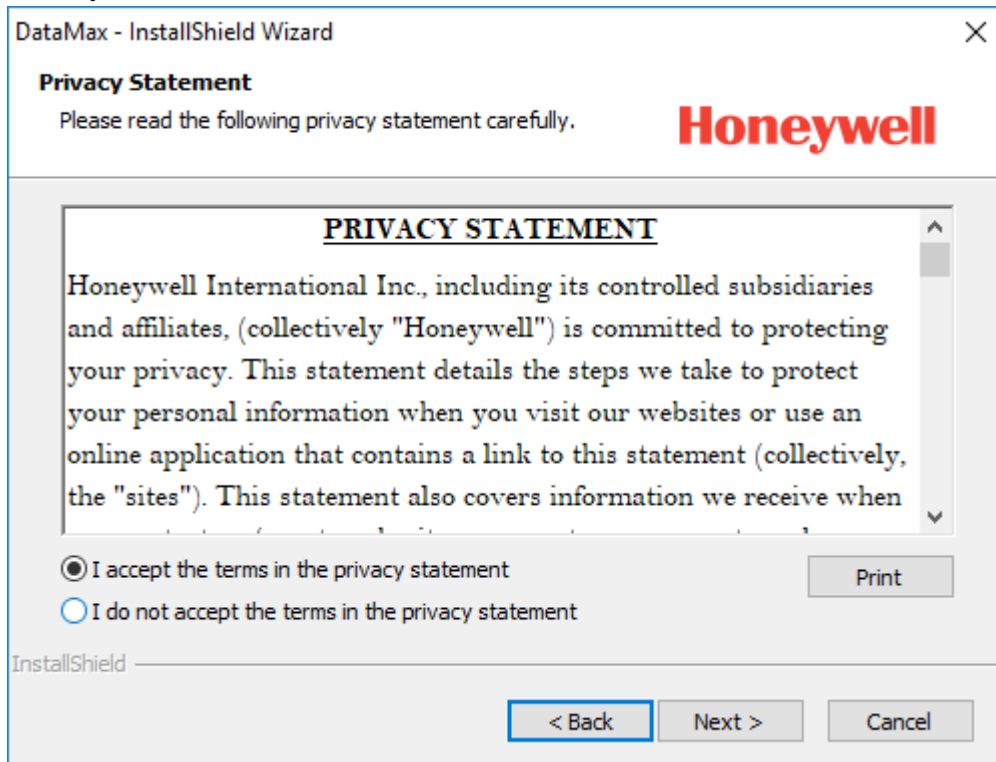

Choose destination location:

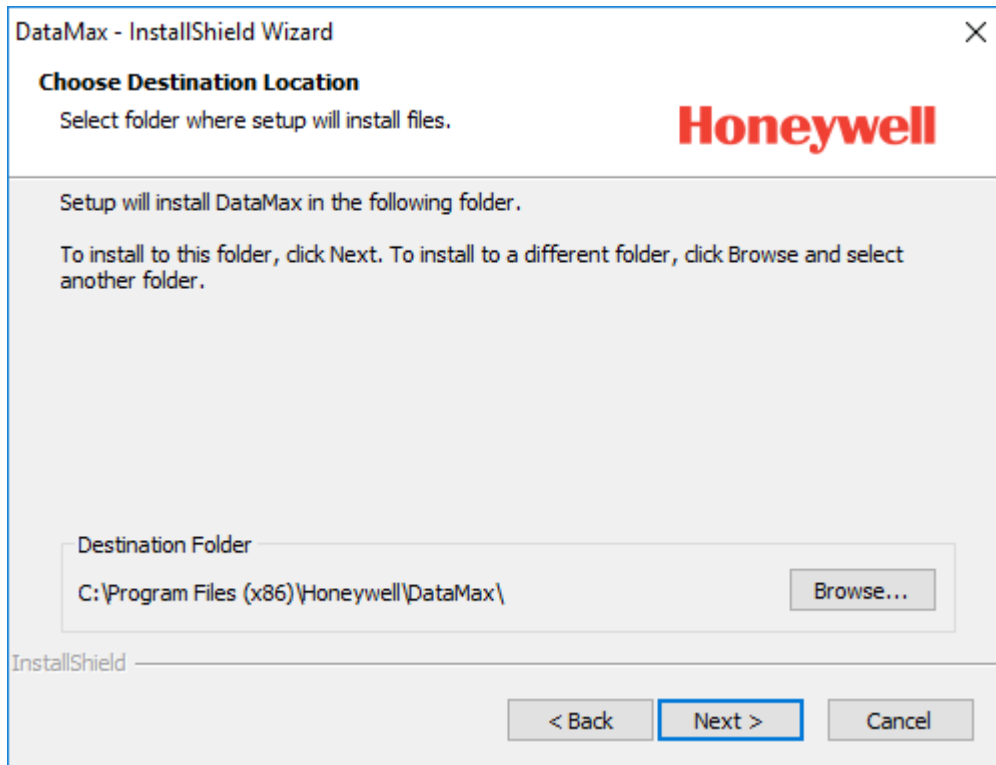

Ready to install program:

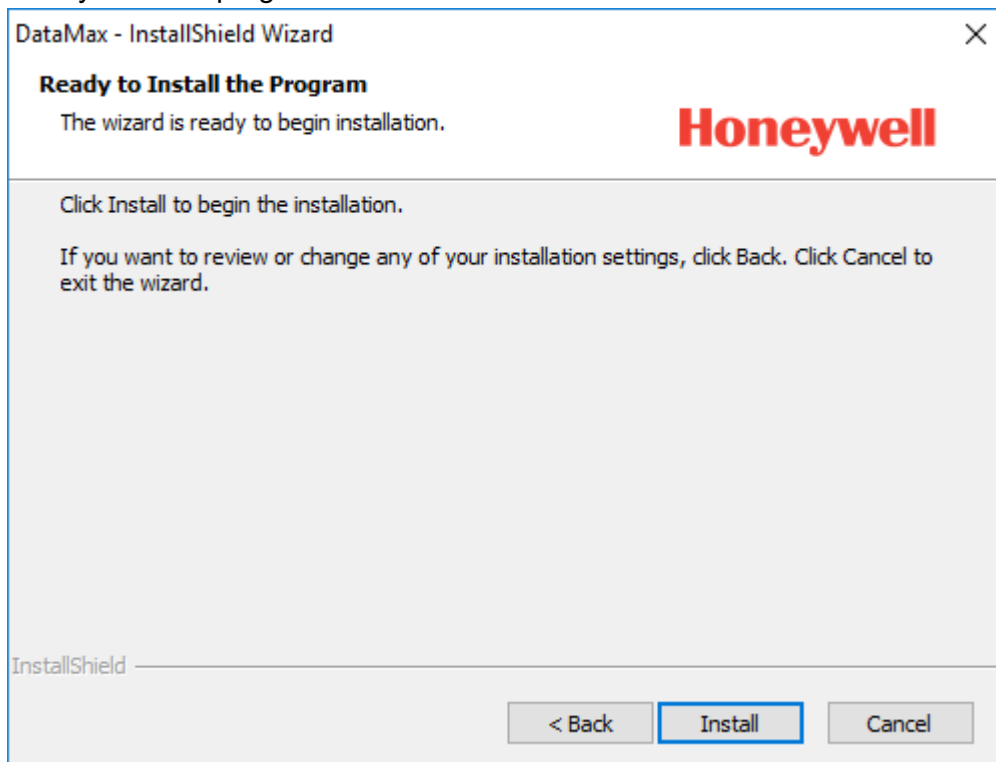

Setup status:

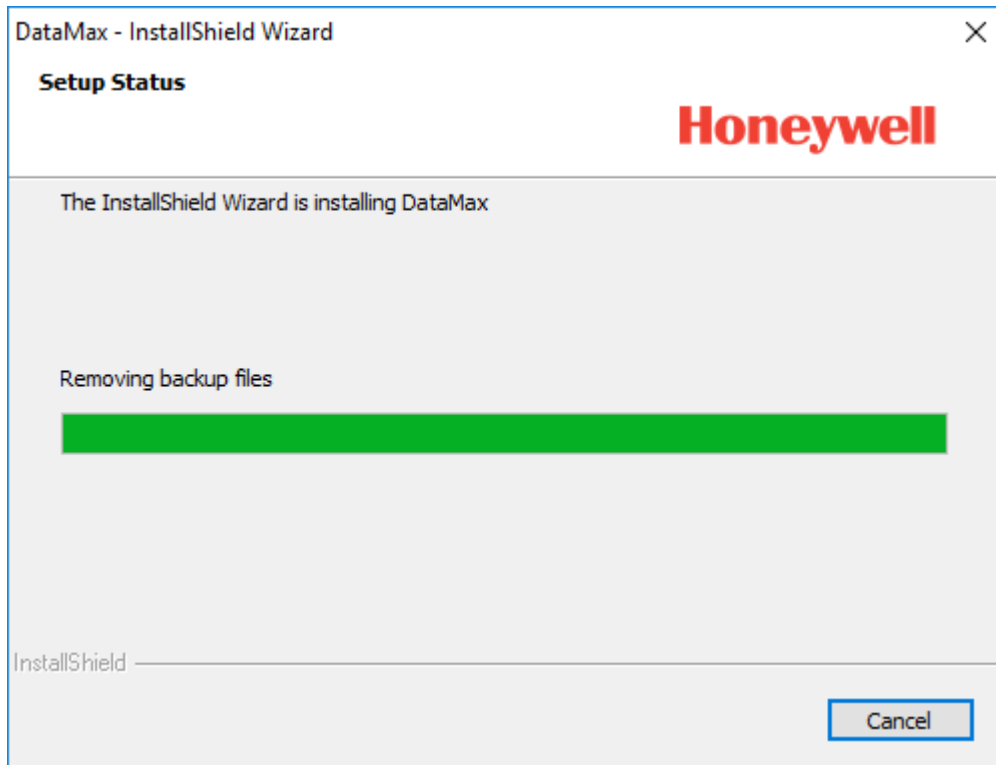

Complete:

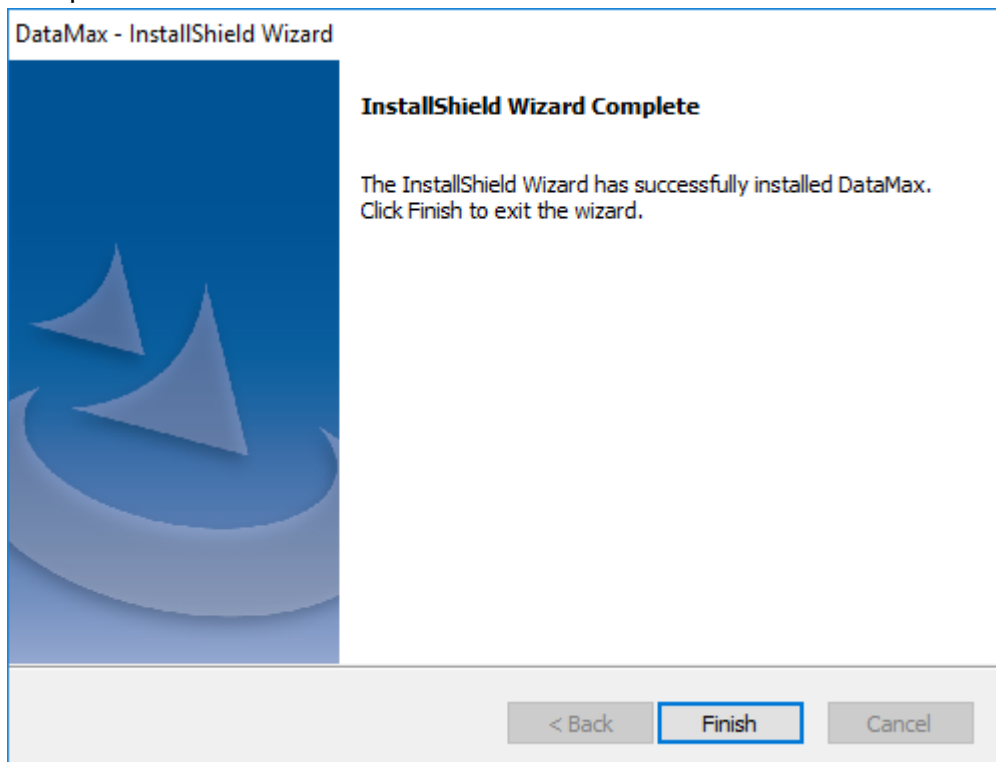

Desktop shortcuts:



Double-click the desktop shortcut to run it:

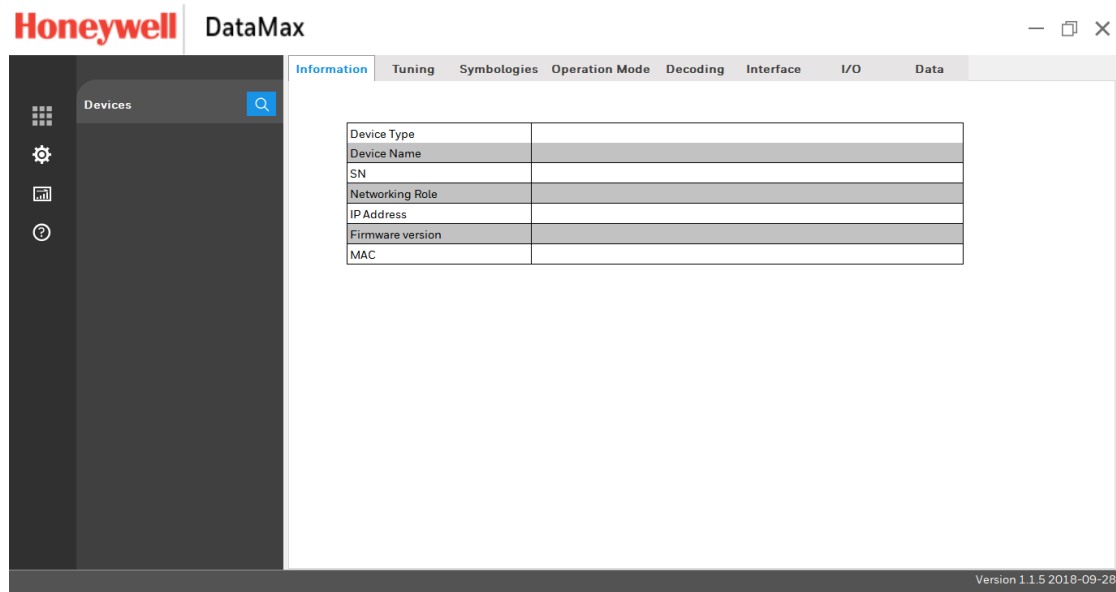

Note: Tool authority will rely on the PC permission.

DataMax[®] User Interface Overview

Device List Area

The device list will be displayed in this area.

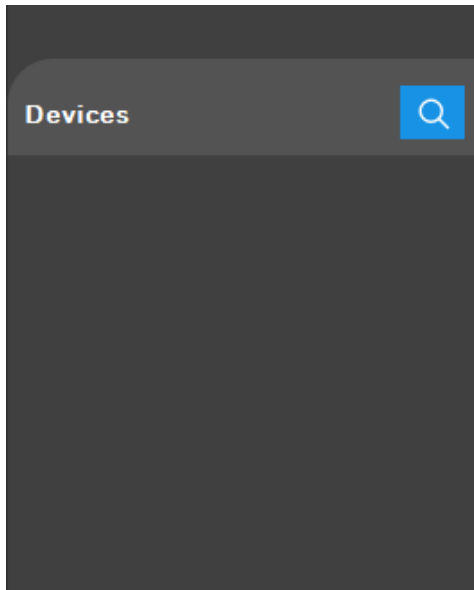

Control and Help Panel

This area shows "Open Configuration", "Save Configuration", "Language", "Log Level", "Update Firmware", "Restart", "User Guide".

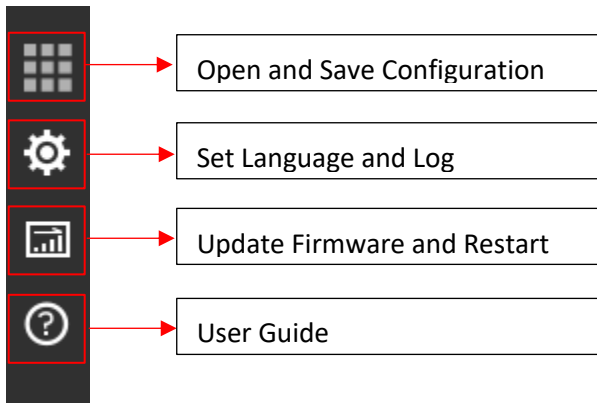

Main Menu and Toolbar

Main Menu:

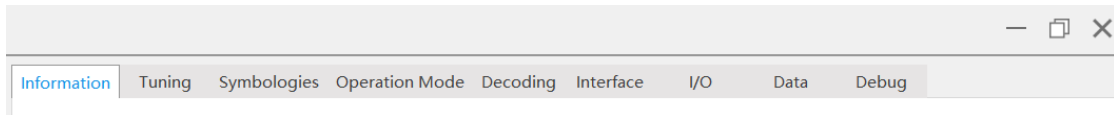

Status bar:



SN number and Device name

DataMax® Version

Device Discovery

Discover under Ethernet

Open the DataMax[®] Configuration Program, click  button, select checkbox Ethernet and click Search button.

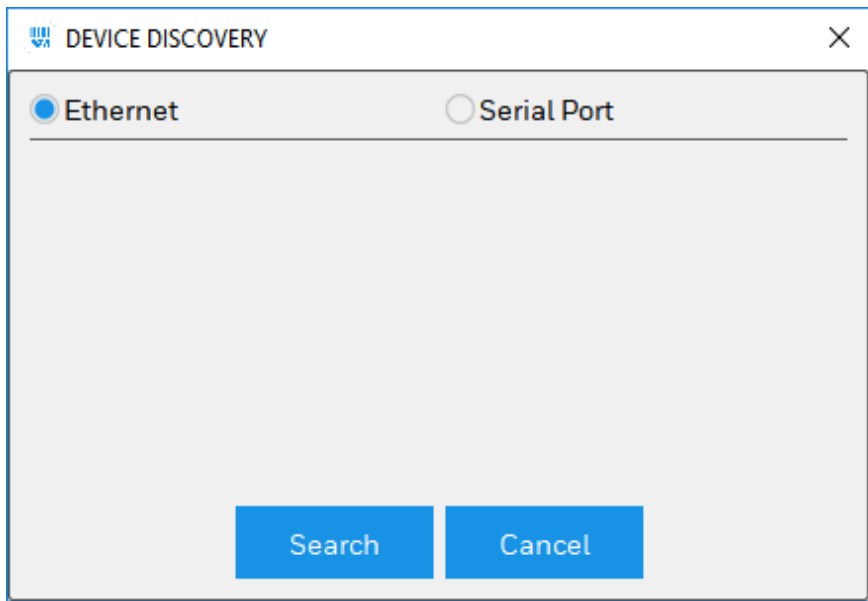

The Program will automatically search all the connected device in the LAN and list its brief information accordingly.

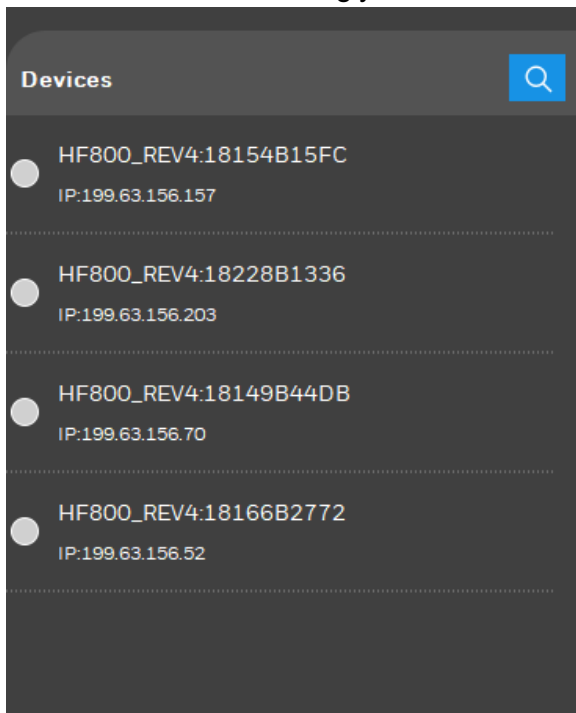

Each item has three parts that users should know.

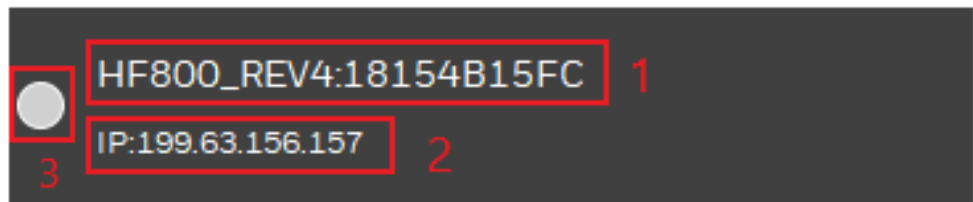

1 Device name and serial number.

2 Device current IP address.

3 Connecting status, grey dot means DataMax[®] Configuration Program has not connected to this device yet, green dot means this device has already connected to DataMax[®] Configuration Program.

If connect to a specified device, double click its item box (or right click and select option connect)

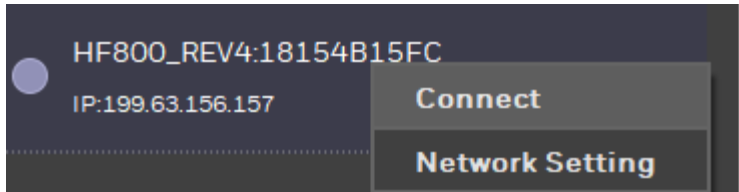

If connected to a device successfully, you will see the device information on the right side of the DataMax[®] Configuration Program.

Device Type	Honeywell HF800
Device Name	HF800_REV4
SN	18154B15FC
Networking Role	Master
IP Address	199.63.156.157
Firmware version	1.0.2
MAC	00-10-20-F8-EC-57

Discover under Serial port

Open the DataMax[®] Configuration Program, click  button, select checkbox Serial Port and click Search button.

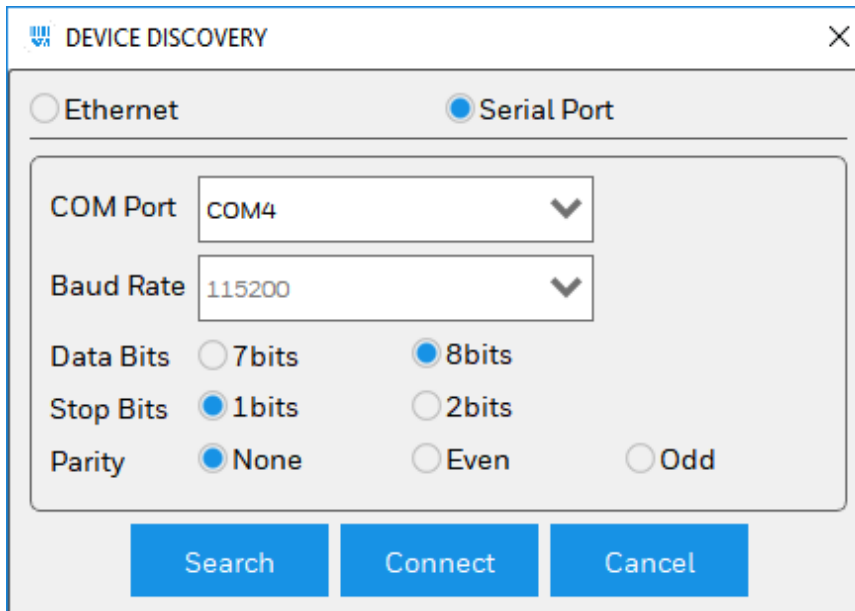

The Program will automatically search all the connected device in the Serial Port. All the connected device serial port will be listed in Com Port. The serial port parameters about Baud Rate, Data Bits, Stop Bits, Parity are manually selected before search.

Click  button, DataMax[®] will list its brief information accordingly.

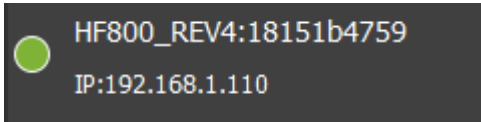

If the device is connected successfully, the device information will be showed on the right side of the DataMax[®] Configuration Program.

Device Type	Honeywell HF800
Device Name	HF800_REV4
SN	18151B4759
Mode	Master
IP Address	192.168.1.110
Firmware version	EC000012BAA

Device Information Description

Select the tab **Information** of DataMax[®], the device information description is shown as follow.

Device Type	Honeywell HF800
Device Name	HF800_REV4
SN	18166B64D1
Mode	Master
IP Address	199.63.156.238
MAC	00-10-20-f8-ec-c2
Firmware version	1.0.0
Kernel version	Linux version 4.1.15+g30278ab SMP PREEMPT Tue Jul 3 15:51:01 CST 2018
App compile time	Aug 14 2018 05:37:56

Imaging Settings & Statistics

When configuring the reader to work in a proper status, a good method is to monitor the images captured by the reader and tune the reader to acquire a better image with proper exposure and gain parameters.

These things could be done through the DataMax[®] Configuration Program.

Open the DataMax[®] Configuration Program and connect to the device first.

Then enter “Tuning” Tab page.

Through this tab page, user can also monitor the decoding results and logging the results.

User can also use the “Auto Train” function to tune parameters of the reader automatically.

Live View

When connect to the device, the live view window will not show images in default and the window will appear to be dark.

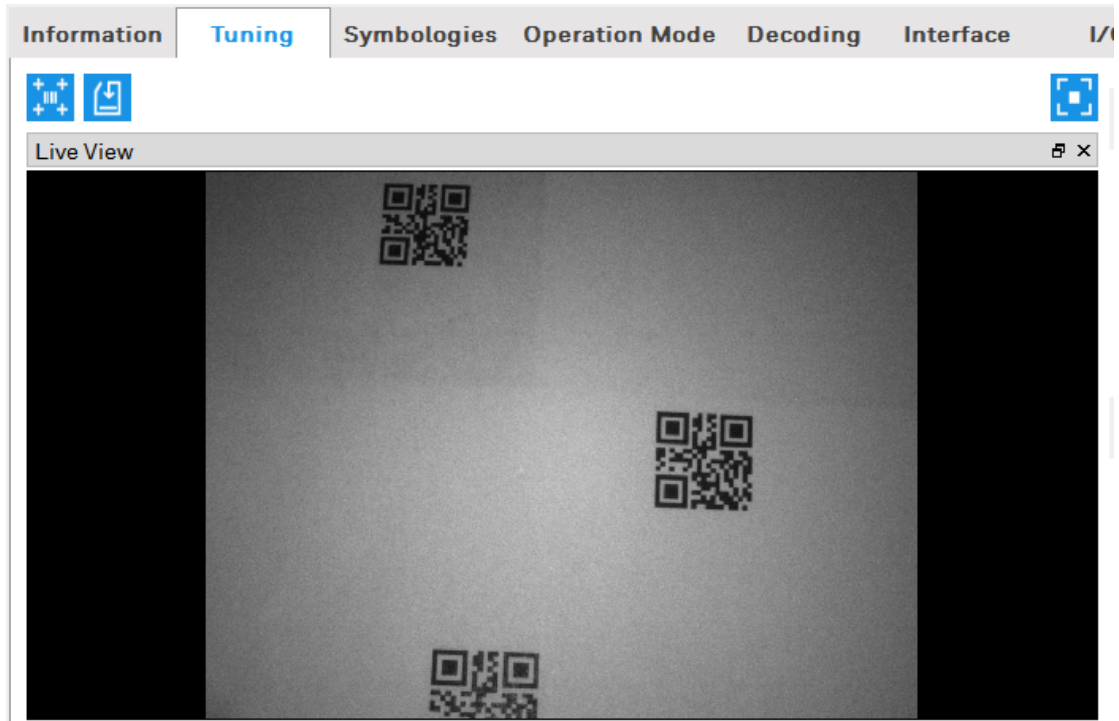

Click the button  to turn on live view function. Then the images captured by the reader will be shown in the window if it is working. Then the button will change to



.Click the button again, the live view function will be turned off.

Log View

This view locates under the Live View window.
All the decoded results information will be listed in this view.

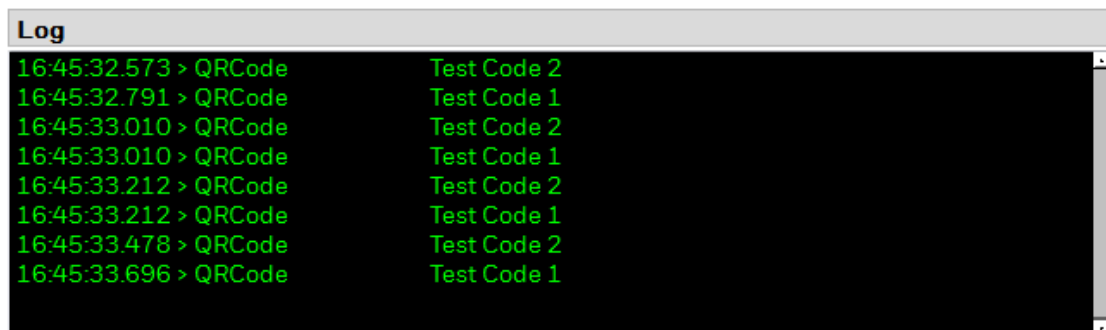

From this window, The barcode received timestamp, barcode type and the contents of the barcode can be get.

Right click in the Log View, a popup menu will appear,

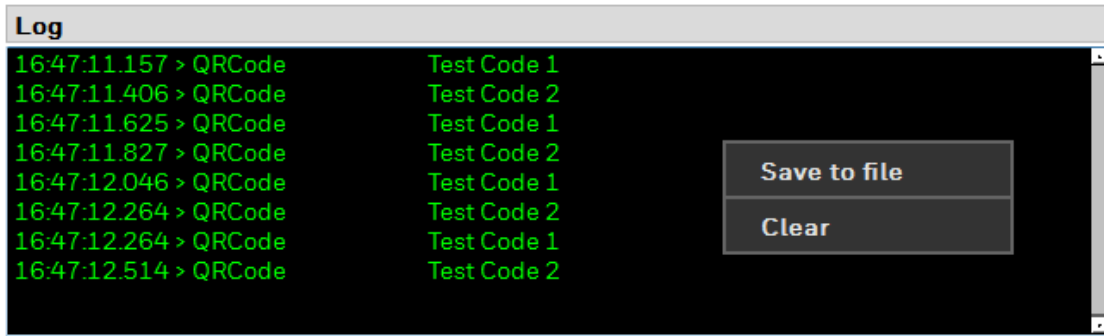

Choose "Save to file" to save the result to specified file.

Choose "Clear" to clear all the information in the Log View window.

Statistics

The "Statistics" panel will show all the current decoding counters.

Through it, user can monitor the decoding rate and average decode times.

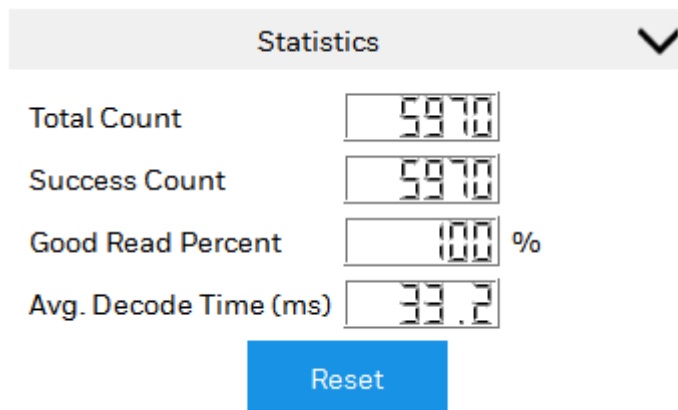

Click the "Reset" button will reset all the counters to zero.

Image Setup

From this panel, the reader's exposure mode could be configured to be auto or fixed.

In auto mode, the reader will adjust the exposure time and gain automatically per the images it captured from the sensor.

If change to fixed mode, the reader's exposure time and gain will be the values typed in the edit box.

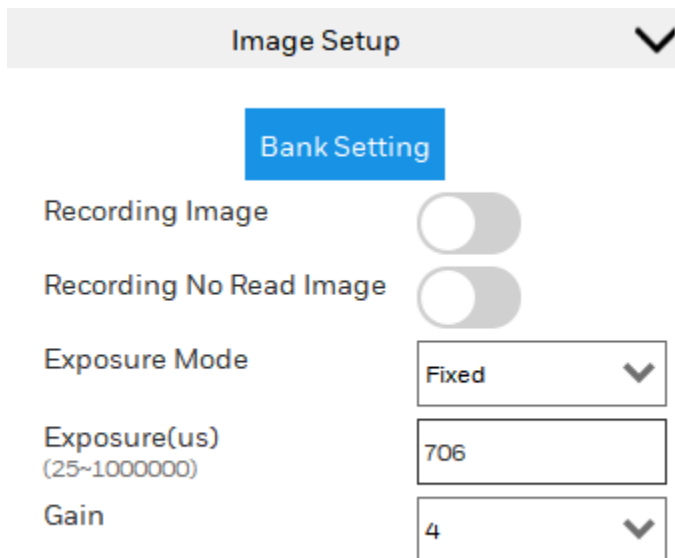

Also in this panel, bank settings could be configured to take effect when reading. In each bank, user could set specific exposure time and gain and choose whether to enable or disable. HF800 support no more than eight banks. If there are more than one enabled banks, reader will switch among different bank settings one by one when reading until read one barcode or timeout occurs.

To set the banks, click the button Bank Setting, a dialog will popup for user to configure the bank settings.

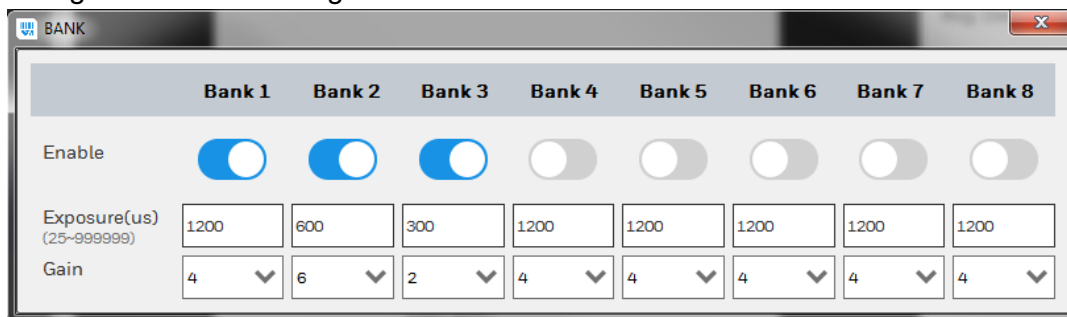

When each specific bank was enabled, the related parameters will take effect immediately.

Note : To make the bank settings take effect, exposure mode should be configured to fixed mode first.

Aimer & Light

From this panel, the illumination and aimer of the reader could be turned on/off separately up to the requirement from the user.

▼
Aimer&Light

Internal illumination

Laser/Led aimer

Auto-Train

HF800 can support Auto-Train function. When execute, it can help to tune the imaging parameters and identify the barcodes in front of the reader's FOV automatically.

This function can help to reduce the distribution time.

▼
Auto-Train

Default
 Customize

Exposure (us) ~

Maximum Gain

Tune

Auto-Train Tuning Steps:

1. Open the DataMax[®] Configuration Program and connect to the device.
2. Go to the "Tuning" Tab page.
3. In the "Auto Train" panel, we can choose the option "Default" or "Customize" to tell the reader how to operate the auto tuning process;

If choose "Default", reader will tune the imaging parameters by itself.

If choose "Customize", user can specify the minimum and maximum value for the exposure time and the maximum gain could be limited to the value in between 1,2,3,4,6,8.

4. Click Auto learn to start the auto learn process.

Note: Suggest to enable the live view function to monitor the whole auto learn process.

Wait for several seconds, reader will give the feedback.

If success, reader will beep for 3 times and a dialog will appear to inform the user.

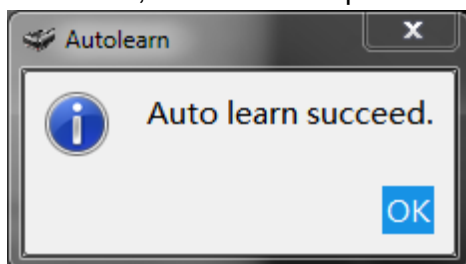

If failed, reader will give an error beep and a dialog will appear to inform the user.

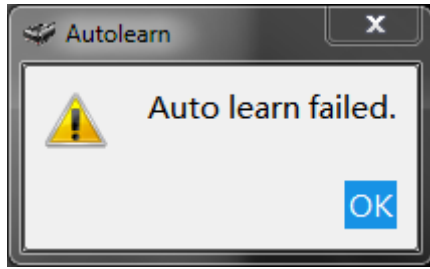



Image Cropping

Sometimes the current barcode position was known before searching, if change the search region from the whole image to a specified small region, it will reduce the decoder's search time and can reduce the decode time as well.

Operating steps:

- 1, Open the DataMax[®] Configuration Program and connect to the device.
 - 2, Switch to Tab page "Tuning", enable the Live View function first.
 - 3, Click  locate on the top left corner.
 - 4, Move the mouse cursor above the Live View window, press and hold the left button to set the top left coordination of the sub window. Then keep the button pressed and move the mouse to draw a red rectangle.
 - 5, When the desired sub-window has been drawn, release the left button.
- When doing this drawing, the coordinations of the window keeps on change at the same time.



Now the reader can only decode the barcodes which locate in this cropped window now.



If do not need to crop the image any more, press  to disable this function.

Image Save

If want to save the image in the live view window, press  can save the image to the specific path on local PC. A dialog will popup for the user to choose the location where to save the image like the picture showed below.

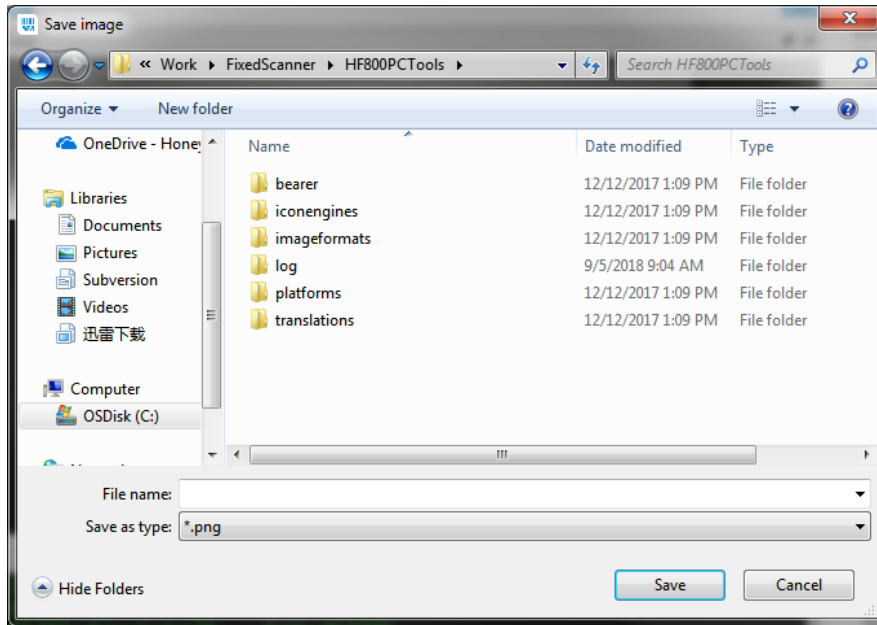

Charts Panel

When the reader is working and live view function is enabled. This panel can demonstrate the statistic values of decode time and good read rate. The axes may look like below images:

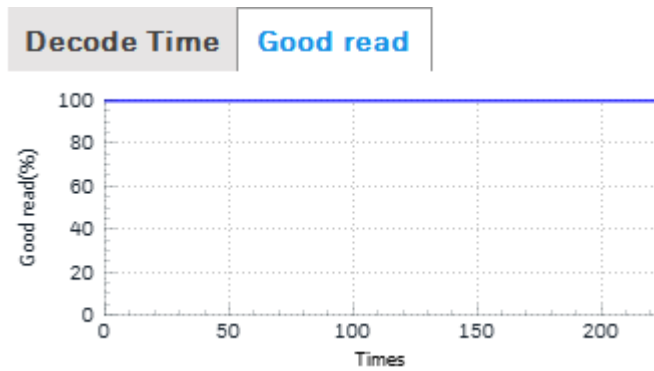

Configurations Loading/Storage

DataMax[®] allows load and storage configurations form/to pc.

Operating steps:

1. Select one device and connect.

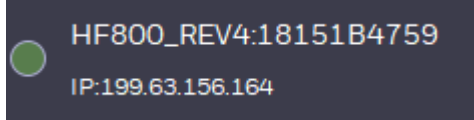

2. Click button  locate on the left of Devices

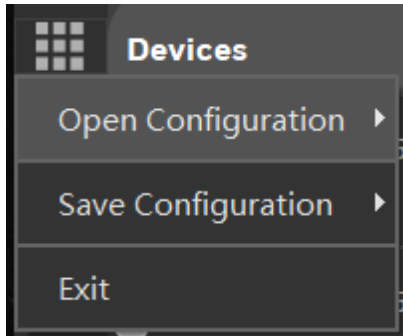

3. To save devices configuration to PC:
 - a. Select "Save Configuration to PC" button.

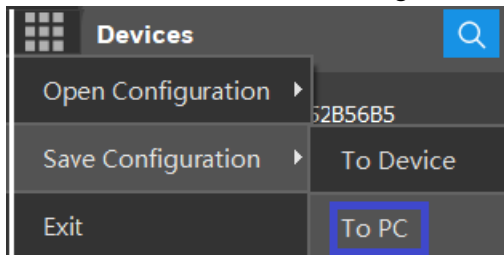

- b. Select the file path and fill in the file name.

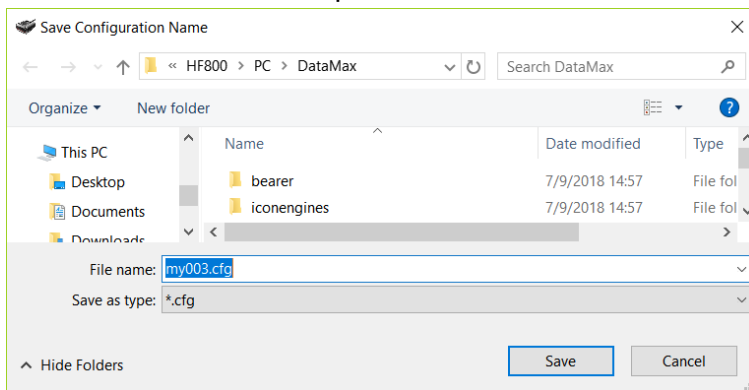

- c. It will notify users that "Save Success".

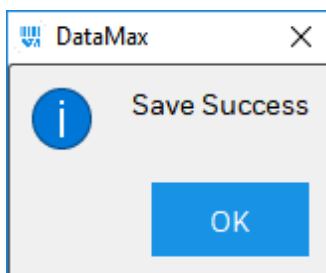

- 4. To load pc configuration to device:
 - a. Select "Open Configuration from local PC".

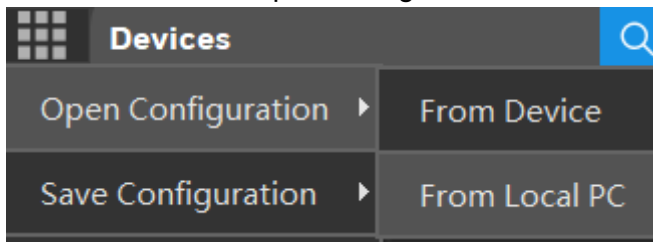

- b. Select the file path and the file name with ".cfg" extend name.

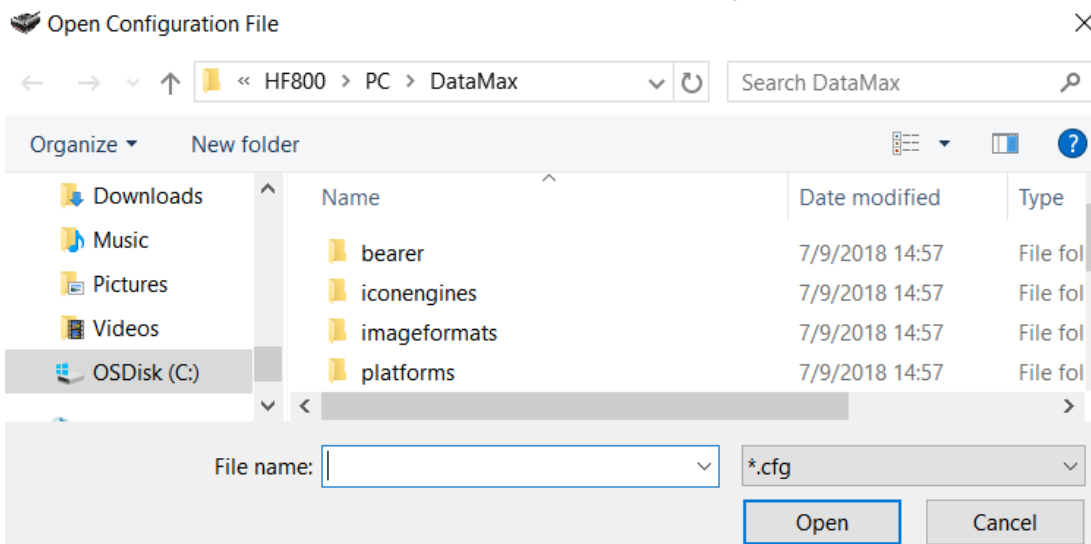

- c. It will notify users that "Load configuration Success".

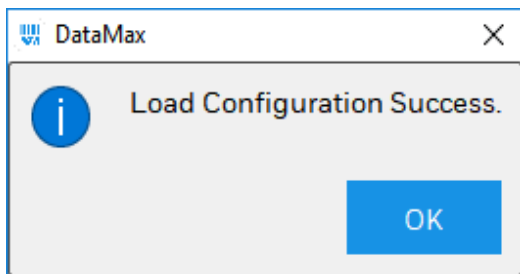

- 5. To save DataMax[®] configuration to device, select "Save Configuration to Device"

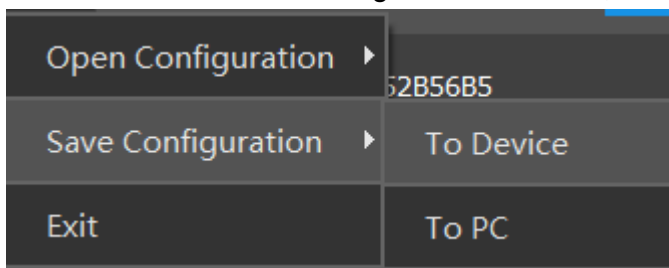

- 6. To load device configuration to DataMax[®], select "Open Configuration from Device"

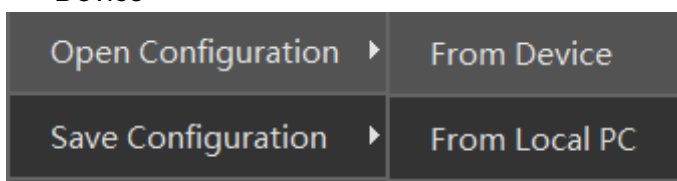

Restore to Default

To return a device to its absolute Factory default parameters it is necessary to use the Restore Factory Defaults Tune. You will be prompted to confirm. All Environment parameters will be restored to Factory default values and any existing configurations stored on the device will be erased. The device will be reset and therefore start in run mode with the factory default configuration.

Operating steps:

1. Keep press the button "Tune" for more than 20s, then release the button, reader will enter the mode waiting for user to confirm the default operation. the "Train" (red/green led) flashing through 5Hz.

2. If press the button again in 10s, the reader will return to default configurations.

If reader return to default configuration success, the beeper will execute a menu configure good tone. The Read led will indicate green.

If doesn't press the button again beyond 10s, the reader will return to previous work states.

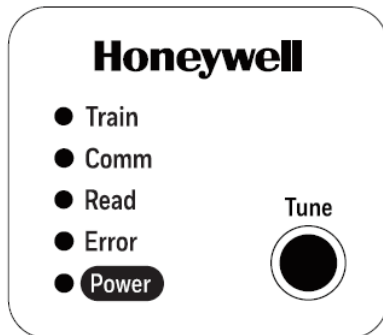

Communication Interface Setup

Network Setup

Open DataMax[®] Configuration Program and connect a device first,

Click  button.

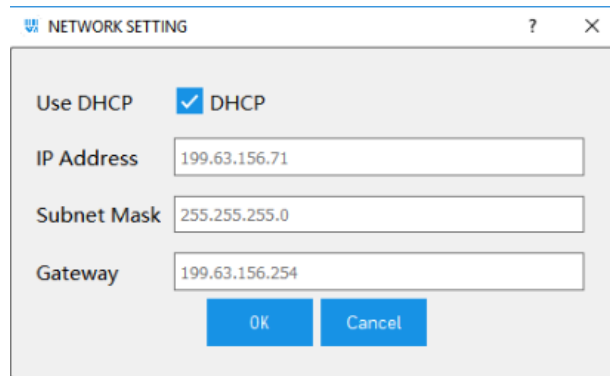

NETWORK SETTING

Use DHCP DHCP

IP Address

Subnet Mask

Gateway

OK Cancel

If DHCP is enabled, IP address subnet and gateway is not available, the device will get IP address subnet address and gateway automatically by DHCP server.

If DHCP is disabled, you can setup static IP address, subnet and gateway

Click Ok button and your settings will be saved in the device and activated after device reboot.

If DHCP is disabled, which means reader use specified static IP address, subnet mask and gateway.

Note:

If want to connect network cable to PC directly, please use the reader to scan configuration barcode “NWKDHP0” first, and scan “RESET_” to reset reader.

Then set a static IP for PC, please follow below settings,

To find the network configuration barcodes, please go to the Appendix A at the end of this manual.

1. Click **Start Menu > Control Panel > Network and Sharing Center**. (For Windows 8 and higher, search for and open Control Panel and select Network and Internet).
2. Click **Change adapter settings**.

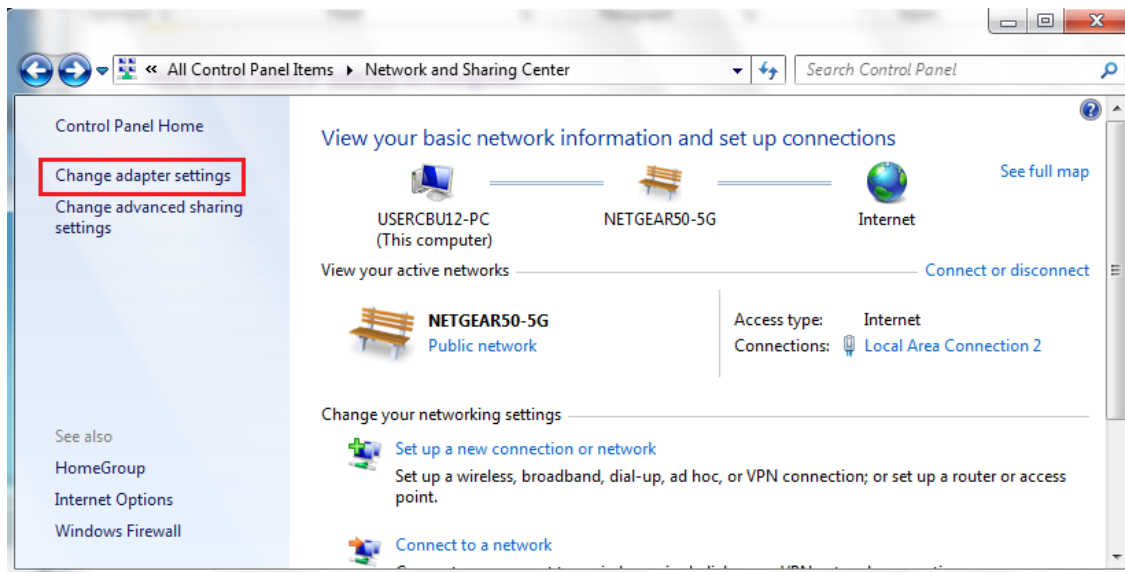

3. Right-click on **Local Area Connection** and click on **Properties**.

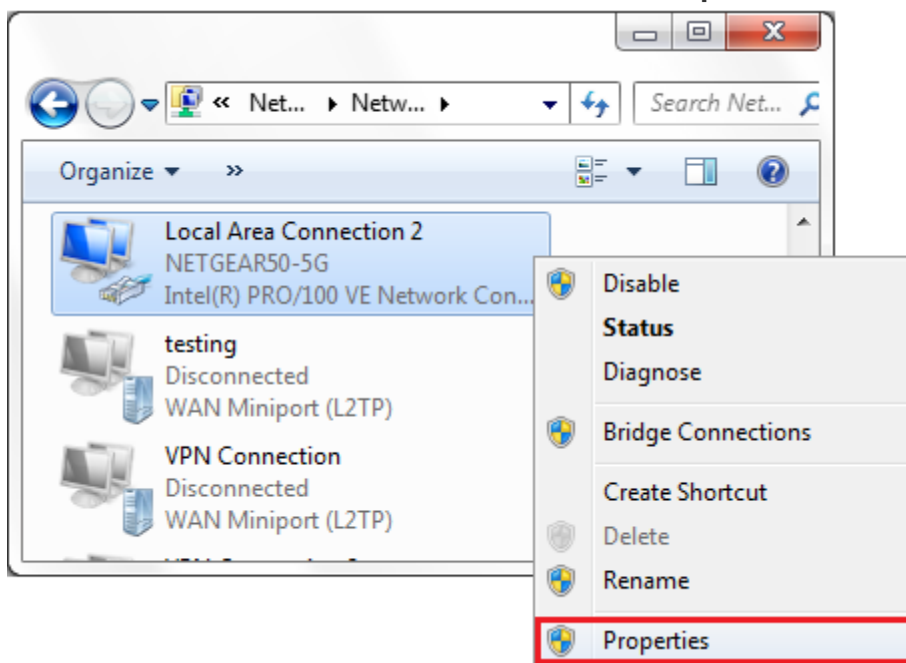

4. Select **Internet Protocol Version 4 (TCP/IPv4)** and click on **Properties**.

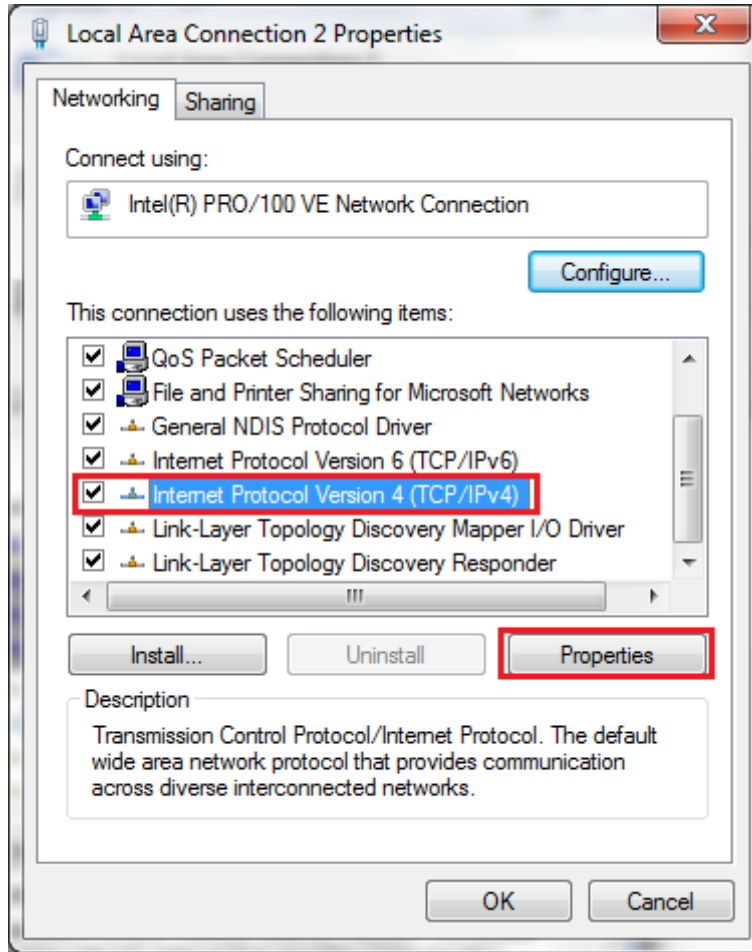

5. Select **"Use the following IP address"** and enter the IP address, Subnet Mask, Default Gateway, and DNS server. Click **OK** and close the **Local Area Connection** properties window. (Reader default IP address is 192.168.1.110, so make user your PC IP address and reader IP address are in the same network segment)

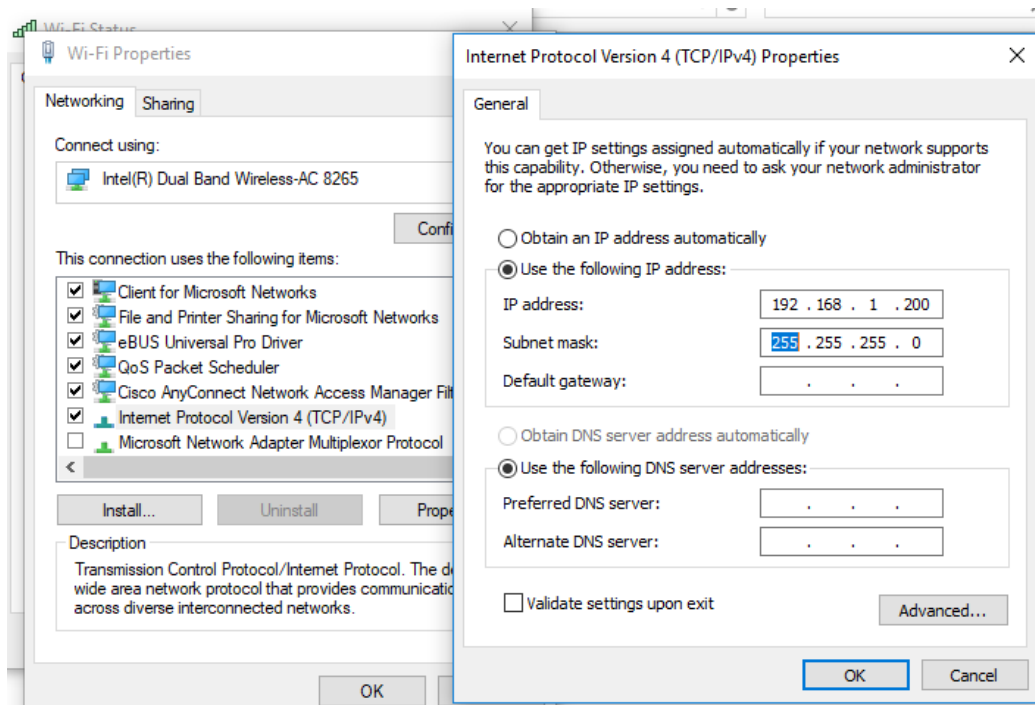

Network Grouping (Master/Slave)

HF800 support network grouping, user could set maximum 8 readers in a group. Network grouping supports 2 modes: Synchronized mode and Pass-through mode. In Synchronized mode, suggest user to use one trigger source to trigger all the HF800s in the group. In Pass-through mode, all the HF800s could be triggered by one source, or be triggered separately.

Open DataMax[®] Configuration Program, connect a device first, select Interface tab and then choose Network tab.

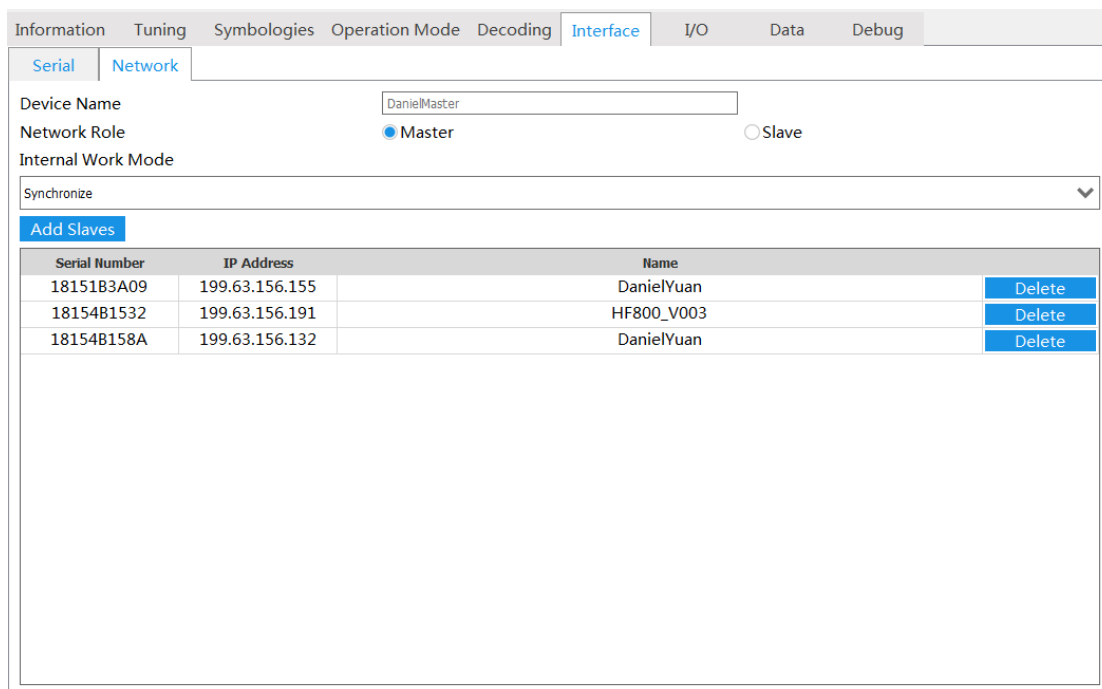

If the device you selected is Master, you can select Master work mode:

1. Synchronize mode: Master will receive data which from slave devices and processing all the data (data format, sequence) and transmit the overall data through Master's interface.

NOTE: Please make sure that master and slaves share the same symbologies settings, if slave decode and transmit one certain symbology to master which master do not support, master will ignore this symbology and send nothing out.

Synchronized mode typical application layout as below:

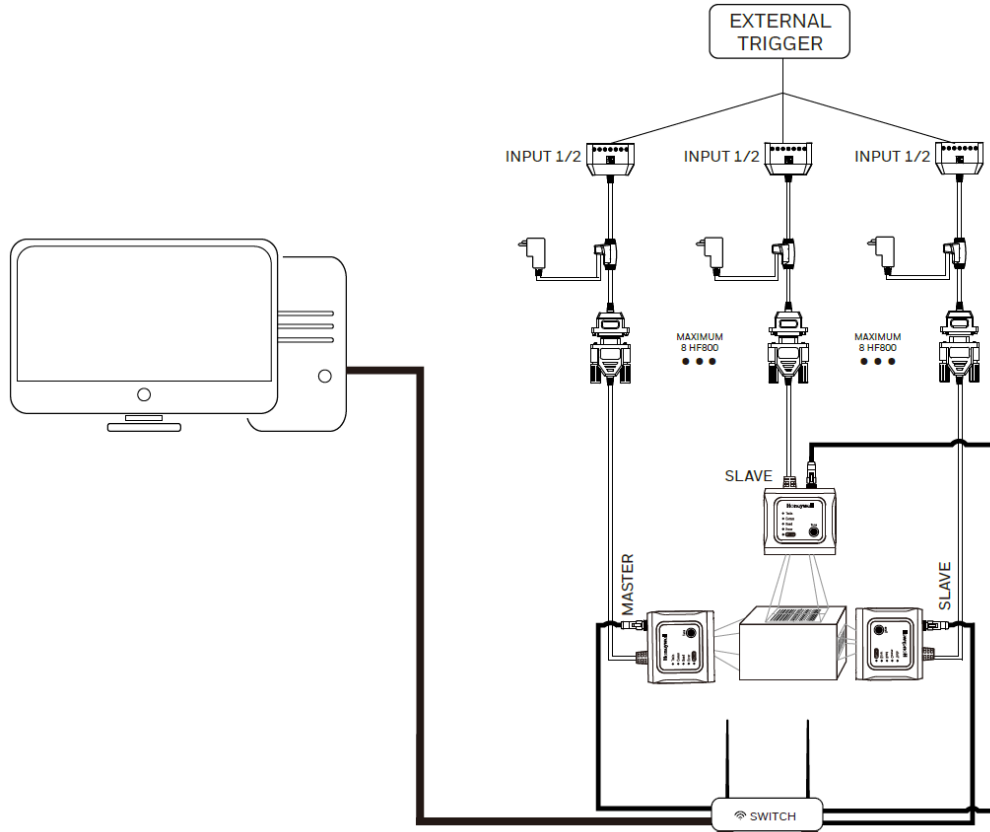

2. Pass-through mode: Master will act as a repeater and transmit all the data which from slave devices without processing through Master's interface.

DataMax[®] Configuration Program will also list current grouping information if the connected device is acted as Master.

Pass-through mode typical application layout as below:

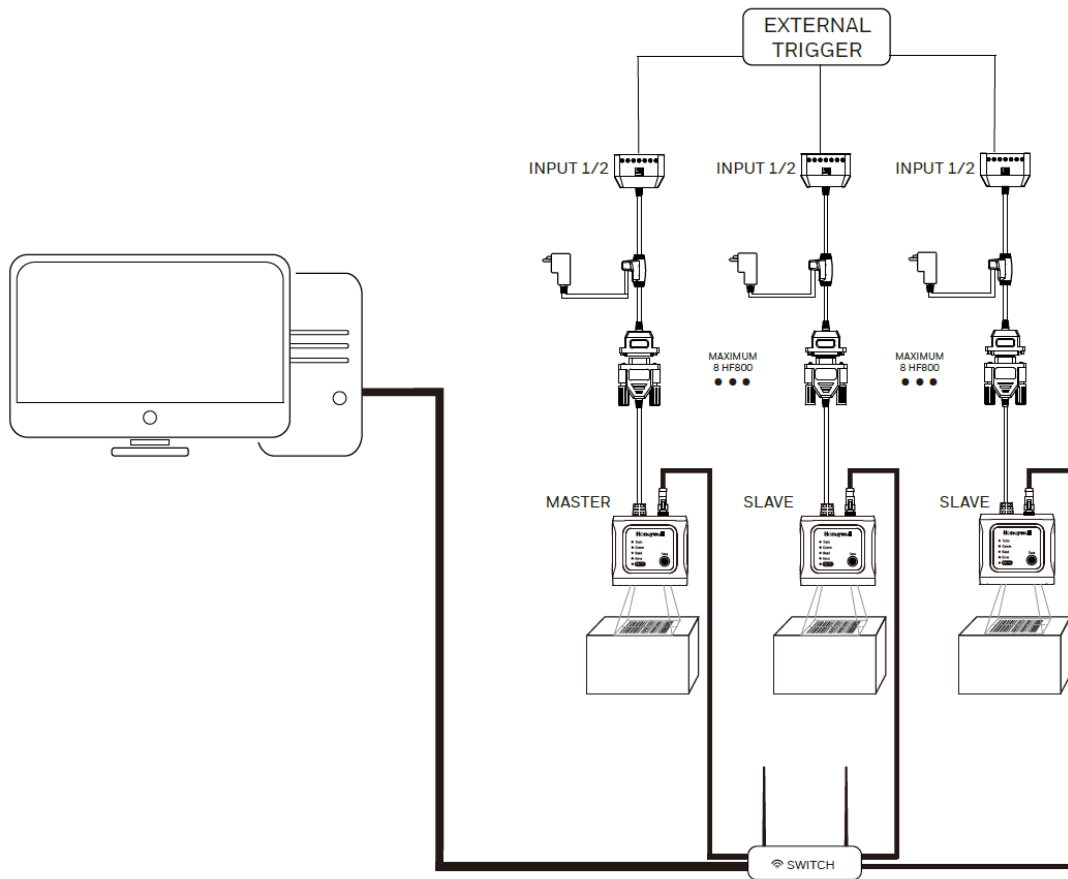

Serial Interface Setup

The Serial interface is used when connecting to the serial port of a PC or terminal.

Select **Interface** tab of the DataMax[®] and click the button **Serial**.

Information	Tuning	Symbologies	Operation Mode	Decoding	Interface	I/O	Data	Debug
Serial		Network						
Baudrate (Default:9)	115200							
Word Format (Default:2)	8 Data Bits 1 Stop Bit No Parity							
XON/XOFF Software Flow Control (Default:0)	<input type="checkbox"/>							
ACK/NAK Software Flow Control (Default:0)	<input type="checkbox"/>							
RS-232 Receiver Time-Out (sec) (Min-Max=0-300 Default:0)	0							
RS-232 Time-Out (ms) (Min-Max=0-5100 Default:3100)	3100							
RTS/CTS Hardware Flow Control (Default:0)	RTS/CTS Off							

1. **Baud rate** sends the data form the reader to the terminal at the specified rate, the host terminal must be set for the same baud rate as the reader. Default = 115200.
2. **Data bits** sets the word length at 7 or 8 bits of data per character. If an application requires only ASCII Hex characters 0 through 7F decimal (text, digits,

and punctuation), select 7 data bits. For applications that require use of the full ASCII set, select 8 data bits per character. Default=8.

3. **Stop bits** sets the stop bits at 1 or 2. Default=1.

4. **Parity** provides a means of checking character bit patterns for validity. Default=None.

5. **XON/XOF** Standard ASCII control characters can be used to tell the reader to start sending data (XON/XOFF On) or to stop sending data (XON/XOFF Off). When the host sends the XOFF character (DC3, hex 13) to the reader, data transmission stops. To resume transmission, the host sends the XON character (DC1, hex11). Data transmission continues where it left off when XOFF was sent, Default=XON/XOFF Off.

6. **ACK/NCK** After transmitting data, the reader waits for an ACK character (hex 06) or a NAK character (hex 15) response from the host. If ACK is received, the communications cycle is completed and the reader looks for more bar codes. If NAK is received, the last set of bar code data is retransmitted and the reader waits for ACK/NCK again.

7. **RS232 Receiver Time-out** The unit stays awake to receive until the RS232 Receiver Time-out expires. When an Rs232 receiver is sleeping, a character may be sent to wake up the receiver and reset the time-out.

8. **RS232 Hardware Flow Control**

It allows control of data transmission from the reader using software commands from the host device. When RTS/CTS is turned off, no data flow control is used.

Flow Control, No Timeout: The reader asserts RTS when it has data to sand, and will wait indefinitely for CTS to be asserted by the host.

Two-Direction Flow Control: The reader asserts RTS when it is OK for the host to transmit. The host asserts CTS when it is OK for the devices to transmit.

Flow Control with Timeout: The reader asserts RTS when it has data to send and waits for a delay (see RS232 Time-out) for CTS to be asserted by the host. If the delay time expires and CTS is not asserted, the device transmit buffer is cleared and scanning may resume. Default=RTS/CTS off.

9. **RS232 Time-out** when using **Flow Control with Timeout**, you must program the length of the delay you want to wait for CTS from the host. Set the length (in milliseconds) for a time-out by scanning the bar code below, then setting the timeout (from 1-5100 milli-seconds).

Operating Mode

Streaming Presentation Mode

When in Streaming Presentation Mode, the reader remains on all the time to continuously search for barcodes. The reader's illumination and aimer can be configured to be on or off.

To configure the reader to work in this mode, open the DataMax[®] Configuration Program and Connect to the specific device first.

Then enter the "Operation Mode" Tab page.

Click the drop menu "Operation Mode" and select "Streaming Presentation".

The reader will enter the streaming presentation mode immediately.

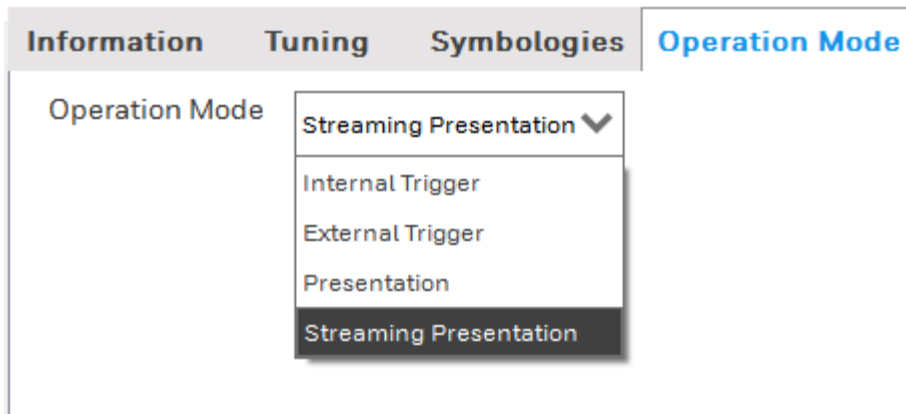

Presentation Mode

Presentation Mode uses ambient light and reader illumination to detect barcodes. When in Presentation Mode, the LEDs remain dim until a barcode is presented to the reader, then the aimer turns on and the LEDs turn on to read the code. If the light level in the room is not high enough, Presentation Mode may not work properly.

To configure the reader to work in this mode, open the DataMax[®] Configuration Program and Connect to the specific device first.

Then enter the "Operation Mode" Tab page.

Click the drop menu "Operation Mode" and select "Presentation".

The reader will enter the Presentation mode immediately.

Note: The parameter “Re-read Delay” is also work in this mode. For details, please go to “Streaming Presentation Mode” for reference.

External Trigger Mode

When in External Trigger Mode, the reader will wait for a trigger signal from external, This signal can be a pulse or a latched electrical level. When the reader detects this signal, it will try to search the barcodes immediately.

The working mode may be chosen from “OneShot”, “Burst” and “Continuous”.

To enable this mode, please enter the “Operation Mode” Tab page first.

Click the drop menu “Operation Mode” and choose “External Trigger”.

The reader will enter external trigger mode immediately.

External Trigger Delay

External Trigger Delay will take effect when an external trigger signal was detected.

If the delay duration is larger than zero, reader will delay for the user specified time value then trigger the reader.

If the delay duration is equal to zero, reader will be triggered immediately.

External Trigger Delay(ms)
(0~2000)

Trigger through remote commands

The reader can also be triggered by sending specified ASCII command via serial or network:

Activate: SYN T CR (ASCII 22 84 13)

Deactivate: SYN U CR (ASCII 22 85 13)

The reader scans until a barcode has been read or until the deactivate command is sent, or until the time-out has been reached.

If user want to customize TCP port for sending trigger command through network., go to Interface tab page, select Network sub tab page modified the port value(default value is 55256).

Customize Trigger TCP Port

OneShot Mode

This is a working mode under external trigger mode.

Choose "One Shot" can enable this mode.

Working Mode

When enabled, the reader will only capture one image and try to decode this image when detects an external trigger signal.

Burst Mode

This is a working mode under external trigger mode.

Choose "Burst" can enable this mode.

Working Mode

When enabled, the reader will start to search barcodes when detects an external trigger signal and will keep in this state no matter the external trigger signal removed or not until one barcode was decoded or the timeout occurs.

Trigger Times
(0-1000)

One important parameter in this mode is “Trigger Times”, When the value is larger than 1, the reader will repeat the barcode reading activity for specific times. In each reading cycle, the reader will acquire one image and try to search the barcodes contained in it. User can set the duration for each reading cycle also, the “Read Timeout” in the Chapter “Decoder Configurations” takes the role for this value.

Continuous Mode

This is a working mode under external trigger mode. Choose “Continue” can enable this mode.

Working Mode

When in this mode, user should keep the external trigger signal pulled once triggered. If user pull out the external trigger signal after triggered, reader will trigger off immediately.

If the reader has read the barcodes or the timeout occurs, the reader will also trigger off although the trigger signal was still on.

Internal Trigger Mode

When set the operation mode to “Internal Trigger”, reader will switch to the Internal Trigger Mode.

In this mode, reader will trigger itself with a user specified time interval infinitely.

For how to set the time interval, please refer to “Read Timeout” in the chapter “Decoder Configuration”.

Information	Tuning	Symbologies	Operation Mode	Decoding
Operation Mode	<div style="border: 1px solid gray; padding: 5px;"> <div style="display: flex; justify-content: space-between; align-items: center;"> External Trigger ▼ </div> <div style="background-color: #f0f0f0; padding: 2px;">Internal Trigger</div> </div>			
Working Mode	<div style="border: 1px solid gray; padding: 5px;"> <div style="display: flex; justify-content: space-between; align-items: center;"> External Trigger ▼ </div> </div>			
Trigger Times (0-1000)	<div style="border: 1px solid gray; padding: 5px;"> <div style="display: flex; justify-content: space-between; align-items: center;"> Presentation ▼ </div> </div>			
External Trigger Delay(ms) (0-2000)	<div style="border: 1px solid gray; padding: 5px;"> <div style="display: flex; justify-content: space-between; align-items: center;"> Streaming Presentation ▼ </div> </div>			
	<div style="display: flex; justify-content: center; gap: 20px;"> Trigger On Trigger Off </div>			

Symbologies

The reader will be configurable such that the reading of each symbol type can be enabled or disabled individually, and features appropriate to specific symbol types can be controlled.

HF800 can choose to support the following symbologies:

Aztec Code, Codabar, Codablock A, Codablock F, Code 11, Code 128, Code 39, Code 93, Data Matrix, EAN/JAN-13, EAN/JAN 8, Interleaved 2 of 5, Matrix 2 of 5, MaxiCode, MicroPDF, PDF417, MSI, QR Code, RSS Expanded, RSS Limited, RSS-14, UPC-A, UPC E, Chinese Sensible(Han Xin) code, Maxicode, DPM code.

Note: For the configuration of single symbology or multiple symbologies of them, please go to the specific part in this chapter.

Message Length Description

Some of the barcode symbologies may need to set the valid reading length. If the data length of the scanned barcode doesn't match the valid reading length, the reader will issue an error tone. You may wish to set the same value for minimum and maximum length to force the reader to read fixed length barcode data.

This helps to reduce the chances of a misread.

EXAMPLE: Decode only those barcodes with a count of 9-20 characters.
Min length = 09, Max length = 20

EXAMPLE: Decode only those barcodes with a count of 15 characters.
Min length = 15, Max length = 15

The minimum and maximum lengths and the defaults are included with the respective symbologies and they can be configured through DataMax[®] Configuration Program separately.

1-D symbologies

Enable/Disable all 1-D symbologies

Open DataMax[®] Configuration Program and connect the device first.

Go to the tab page "Symbologies" and click the "Linear" sub page.

Check the check box "Check All" will enable all the 1-D symbologies present in the list.

Uncheck it will disable all the 1-D symbologies present in the list.

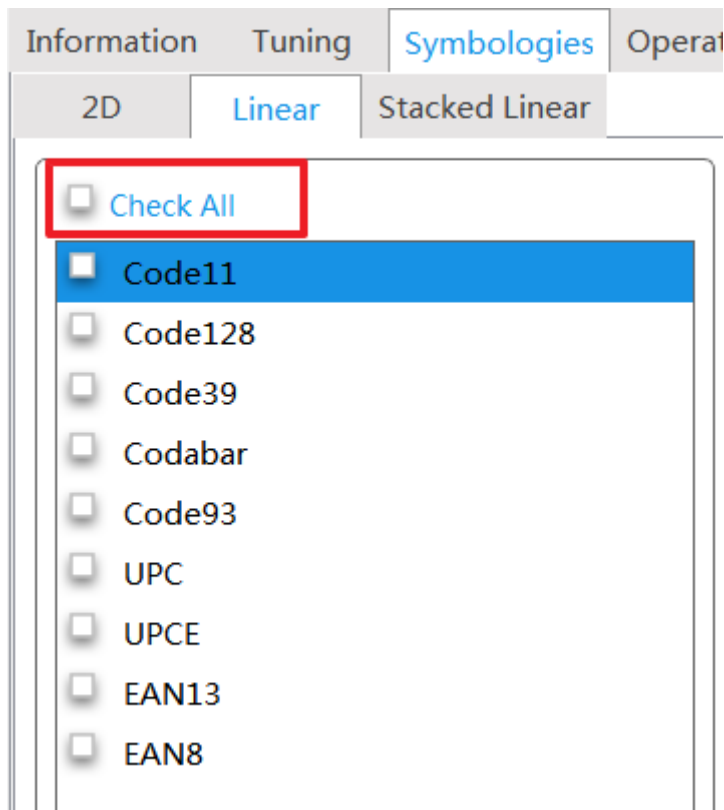

Code 11

Click the “Code 11” in the left list then all its related parameters will be shown on the right.

Code11

Redundant times (Default:0)	0
Minimum Length (Default:4)	4
Maximum Length (Default:80)	80
Two Check Digits (Default:1)	1

Redundant times: output the decode result only when got identical barcodes information for specific times.

Minimum Length: output the decode result when the symbology length equal or larger than the minimum length.

Maximum Length: output the decode result when the symbology length equal or shorter than the maximum length.

Check Digits: This option set whether 1 or 2 check digits are required with Code 11 barcode.

Code 128

Click the “Code 128” in the left list then all its related parameters will be shown on the right.

Code128

Redundant times (Default:0)	<input type="text" value="0"/>
Minimum Length (Default:0)	<input type="text" value="0"/>
Maximum Length (Default:80)	<input type="text" value="80"/>
Append Mode (Default:1)	<input checked="" type="checkbox"/>
Function Code Transmit (Default:0)	<input type="checkbox"/>
ISBT Decoding (Default:0)	<input type="checkbox"/>

Redundant times: output the decode result only when got identical barcodes information for specific times.

Minimum Length: output the decode result when the symbology length equal or larger than the minimum length.

Maximum Length: output the decode result when the symbology length equal or shorter than the maximum length.

Append Mode: This function allows the HF800 to append the data from several Code 128 bar codes together before transmitting them to the host computer. When the HF800 encounters a Code 128 bar code with the append trigger character(s), it buffers Code 128 bar codes until it reads a Code 128 bar code that does not have the append trigger. The data is then transmitted in the order in which the bar codes were read (FIFO).

Function Code Transmit: If enabled, the hex value for the function character will be sent out in the data stream. For 128 Function 1, Function 2, Function 3, Function 4 all cause special things to happen per the ISO Specification. If enabled, this setting causes Function 1, 2 and 4 to be ignored and sent out raw. This does not apply to function 3 as that signifies a menu command in code 128.

ISBT Decoding: The ISBT 128 Application Specification describes 1) the critical data elements for labeling blood products, 2) the current recommendation to use Code 128 due to its high degree of security and its space-efficient design, 3) a variation of Code 128 that supports concatenation of neighboring symbols, and 4) the standard layout for bar codes on a blood product label.

Code 39

Click the "Code 39" in the left list then all its related parameters will be shown on the right.

Code39

Redundant times (Default:0)	<input type="text" value="0"/>
Minimum Length (Default:0)	<input type="text" value="0"/>
Maximum Length (Default:48)	<input type="text" value="48"/>
Transmit Start/Stop Characters (Default:0)	<input type="checkbox"/>
Check Character (Default:0)	<input type="text" value="No check"/> ▼
Append Mode (Default:0)	<input type="checkbox"/>
Full ASCII Mode (Default:0)	<input type="checkbox"/>
Code 32 (PARAF) Decoding (Default:0)	<input type="checkbox"/>

Redundant times: output the decode result only when got identical barcodes information for specific times.

Minimum Length: output the decode result when the symbology length equal or larger than the minimum length.

Maximum Length: output the decode result when the symbology length equal or shorter than the maximum length.

Transmit Start/Stop Characters: Start/Stop characters identify the leading and trailing ends of the bar code. You may either transmit, or not transmit Start/Stop characters.

Check Character: No Check Character indicates that the HF800 reads and transmits bar code data with or without a check character. When Check Character is set to **Validate, but Don't Transmit**, the unit only reads Code 39 bar codes printed with a check character, but does not transmit the check character with the scanned data. When Check Character is set to **Validate and Transmit**, the HF800 only reads Code 39 bar codes printed with a check character, and transmits this character at the end of the scanned data.

Append Mode: This function allows the HF800 to append the data from several Code 39 bar codes together before transmitting them to the host computer. When the HF800 encounters a Code 39 bar code with the append trigger character(s), it buffers Code 39 bar codes until it reads a Code 39 bar code that does not have the append trigger. The data is then transmitted in the order in which the bar codes were read (FIFO).

Full ASCII Mode: If Full ASCII Code 39 decoding is enabled, certain character pairs within the bar code symbol are interpreted as a single character. For example: \$V is decoded as the ASCII character SYN, and /C is decoded as the ASCII character #.

Full ASCII Table													
NUL	%U	DLE	\$P	SP SPACE	0 0	@	%V	P	P	'	%W	p	+P
SOH	\$A	DC1	\$Q	! /A	1 1	A	A	Q	Q	a	+A	q	+Q
STX	\$B	DC2	\$R	" /B	2 2	B	B	R	R	b	+B	r	+R
ETX	\$C	DC3	\$S	# /C	3 3	C	C	S	S	c	+C	s	+S
EOT	\$D	DC4	\$T	\$ /D	4 4	D	D	T	T	d	+D	t	+T
ENQ	\$E	NAK	\$U	% /E	5 5	E	E	U	U	e	+E	u	+U
ACK	\$F	SYN	\$V	& /F	6 6	F	F	V	V	f	+F	v	+V
BEL	\$G	ETB	\$W	' /G	7 7	G	G	W	W	g	+G	w	+W
BS	\$H	CAN	\$X	(/H	8 8	H	H	X	X	h	+H	x	+X
HT	\$I	EM	\$Y) /I	9 9	I	I	Y	Y	i	+I	y	+Y
LF	\$J	SUB	\$Z	* /J	: /Z	J	J	Z	Z	j	+J	z	+Z
VT	\$K	ESC	%A	+ /K	; %F	K	K	[%K	k	+K	{	%P
FF	\$L	FS	%B	, /L	< %G	L	L	\	%L	l	+L		%Q
CR	\$M	GS	%C	- -	= %H	M	M]	%M	m	+M	}	%R
SO	\$N	RS	%D	. .	> %I	N	N	^	%N	n	+N	~	%S
SI	\$O	US	%E	/ /O	? %J	O	O	_	%O	o	+O	DEL	%T

Character pairs /M and /N decode as a minus sign and period respectively.
 Character pairs /P through /Y decode as 0 through 9.

Code 32(PARAF) Decoding: Code 32 Pharmaceutical is a form of the Code 39 symbology used by Italian pharmacies. This symbology is also known as PARAF.

Interleaved 2 of 5

Click the "Interleaved 2 of 5" in the left list then all its related parameters will be shown on the right.

Minimum Length: output the decode result when the symbology length equal or larger than the minimum length.

Maximum Length: output the decode result when the symbology length equal or shorter than the maximum length.

Check Digit: No Check Digit indicates that the HF800 reads and transmits bar code data with or without a check digit. When Check Digit is set to **Validate, but Don't Transmit**, the unit only reads Interleaved 2 of 5 bar codes printed with a check digit, but does not transmit the check digit with the scanned data. When Check Digit is set to **Validate and Transmit**, the HF800 only reads Interleaved 2 of 5 bar codes printed with a check digit, and transmits this digit at the end of the scanned data.

GS1-128

Click the "GS1-128" in the left list then all its related parameters will be shown on the right.

Minimum Length: output the decode result when the symbology length equal or larger than the minimum length.

Maximum Length: output the decode result when the symbology length equal or shorter than the maximum length.

Codabar

Click the “Codabar” in the left list then all its related parameters will be shown on the right.

Codabar

Redundant times (Default:0)	<input type="text" value="0"/>
Minimum Length (Default:4)	<input type="text" value="4"/>
Maximum Length (Default:60)	<input type="text" value="60"/>
Transmit Start/Stop Characters (Default:0)	<input type="checkbox"/>
Check Character (Default:0)	<input type="text" value="No check"/> ▼

Redundant times: output the decode result only when got identical barcodes information for specific times.

Minimum Length: output the decode result when the symbology length equal or larger than the minimum length.

Maximum Length: output the decode result when the symbology length equal or shorter than the maximum length.

Transmit Start/Stop Characters: Start/Stop characters identify the leading and trailing ends of the bar code. You may either transmit, or not transmit Start/Stop characters.

Check Character: Codabar check characters are created using different “modulos.” You can program the HF800 to read only Codabar bar codes with Modulo 16 check characters. **No Check Character** indicates that the HF800 reads and transmits bar code data with or without a check character. When Check Character is set to **Validate and Transmit**, the HF800 only reads Codabar bar codes printed with a check character, and transmits this character at the end of the scanned data. When Check Character is set to **Validate, but Don’t Transmit**, the HF800 only reads Codabar bar codes printed *with* a check character, but does not transmit the check character with the scanned data.

Code 93

Click the “Code 93” in the left list then all its related parameters will be shown on the right.

Code93

Redundant times (Default:0)	<input type="text" value="0"/>
Minimum Length (Default:4)	<input type="text" value="0"/>
Maximum Length (Default:60)	<input type="text" value="80"/>
Append Mode (Default:0)	<input type="checkbox"/>

Redundant times: output the decode result only when got identical barcodes information for specific times.

Minimum Length: output the decode result when the symbology length equal or larger than the minimum length.

Maximum Length: output the decode result when the symbology length equal or shorter than the maximum length.

Append Mode: This function allows the HF800 to append the data from several Code 93 bar codes together before transmitting them to the host computer. When this function is enabled, the HF800 stores those Code 93 bar codes that start with a space (excluding the start and stop symbols), and does not immediately transmit the data. The HF800 stores the data in the order in which the bar codes are read, deleting the first space from each. The HF800 transmits the appended data when it reads a Code 93 bar code that starts with a character other than a space.

UPC-A

Click the "UPC-A" in the left list then all its related parameters will be shown on the right.

UPC

Redundant times (Default:0)	<input type="text" value="0"/>
Convert UPC-A to EAN13 (Default:1)	<input type="checkbox"/>
Check Digit Transmit (Default:1)	<input checked="" type="checkbox"/>
Number System Digit Transmit (Default:1)	<input checked="" type="checkbox"/>
2 Digit Addenda (Default:0)	<input type="checkbox"/>
5 Digit Addenda (Default:0)	<input type="checkbox"/>
Addenda Required (Default:0)	<input type="checkbox"/>
Addenda Separator (Default:1)	<input checked="" type="checkbox"/>

Redundant times: output the decode result only when got identical barcodes information for specific times.

Convert UPC-A to EAN13: When **UPC-A Converted to EAN-13** is selected, UPC-A bar codes are converted to 13 digit EAN-13 codes by adding a zero to the front. When **Do not Convert UPC-A** is selected, UPC-A codes are read as UPC-A.

Check Digit Transmit: This selection allows you to specify whether the check digit should be transmitted at the end of the scanned data or not.

Number System Digit Transmit: The numeric system digit of a U.P.C. symbol is normally transmitted at the beginning of the scanned data, but can be programmed so it is not transmitted (**Off**).

2/5 Digit Addenda: This selection adds 2 or 5 digits to the end of all scanned UPC-A data.

Addenda Required: When Required is set, the HF800 only reads UPC-A bar codes that have addenda.

Addenda Separator: When this feature is On, there is a space between the data from the bar code and the data from the addenda. When turned Off, there is no space.

UPC-E

Click the “UPC-E” in the left list then all its related parameters will be shown on the right.

UPCE

Redundant times (Default:0)	<input type="text" value="0"/>
E0 Decoding (Default:1)	<input type="checkbox"/>
E1 Decoding (Default:0)	<input type="checkbox"/>
E Expand (Default:0)	<input type="checkbox"/>
E Check Digit Transmit (Default:1)	<input checked="" type="checkbox"/>
UPC-E0 Leading Zero (Default:1)	<input checked="" type="checkbox"/>
2 Digit Addenda (Default:0)	<input type="checkbox"/>
5 Digit Addenda (Default:0)	<input type="checkbox"/>
Addenda Required (Default:0)	<input type="checkbox"/>
Addenda Separator (Default:1)	<input checked="" type="checkbox"/>

Redundant times: output the decode result only when got identical barcodes information for specific times.

E0 / E1 Decoding: Most U.P.C. bar codes lead with the 0 number system. For these codes, use UPC-E0.If you need to read codes that lead with the 1 number system, use the UPC-E1 On selection.

E Expand: UPC-E Expand expands the UPC-E code to the 12 digit, UPC-A format.

E Check Digit Transmit: Check Digit specifies whether the check digit should be transmitted at the end of the scanned data or not.

UPC-E0 Leading Zero: This feature allows the transmission of a leading zero (0) at the beginning of scanned data.

2/5 Digit Addenda: This selection adds 2 or 5 digits to the end of all scanned UPC-E data.

Addenda Required: When Required is set, the HF800 only reads UPC-E bar codes that have addenda.

Addenda Separator: When this feature is On, there is a space between the data from the bar code and the data from the addenda. When turned Off, there is no space.

EAN-8

Click the “EAN-8” in the left list then all its related parameters will be shown on the right.

EAN8

Redundant times (Default:0)	<input type="text" value="0"/>
Check Digit Transmit (Default:1)	<input type="checkbox"/>
2 Digit Addenda (Default:0)	<input type="checkbox"/>
5 Digit Addenda (Default:0)	<input type="checkbox"/>
Addenda Required (Default:0)	<input type="checkbox"/>
Addenda Separator (Default:1)	<input type="checkbox"/>

Redundant times: output the decode result only when got identical barcodes information for specific times.

Check Digit Transmit: This selection allows you to specify whether the check digit should be transmitted at the end of the scanned data or not.

2/5 Digit Addenda: This selection adds 2 or 5 digits to the end of all scanned EAN-8 data.

Addenda Required: When Required is set, the HF800 only reads EAN-8 bar codes that have addenda.

Addenda Separator: When this feature is On, there is a space between the data from the bar code and the data from the addenda. When turned Off, there is no space.

EAN-13

Click the “EAN-13” in the left list then all its related parameters will be shown on the right.

EAN13

Redundant times (Default:0)	<input type="text" value="0"/>
Check Digit Transmit (Default:1)	<input type="checkbox"/>
2 Digit Addenda (Default:0)	<input type="checkbox"/>
5 Digit Addenda (Default:0)	<input type="checkbox"/>
Addenda Required (Default:0)	<input type="checkbox"/>
Addenda Separator (Default:1)	<input type="checkbox"/>
ISBN On (Default:0)	<input type="checkbox"/>

Redundant times: output the decode result only when got identical barcodes information for specific times.

Check Digit Transmit: This selection allows you to specify whether the check digit should be transmitted at the end of the scanned data or not.

2/5 Digit Addenda: This selection adds 2 or 5 digits to the end of all scanned EAN-13 data.

Addenda Required: When Required is set, the HF800 only reads EAN-13 bar codes that have addenda.

Addenda Separator: When this feature is On, there is a space between the data from the bar code and the data from the addenda. When turned Off, there is no space.

ISBN On: When On is set, EAN-13 Bookland symbols are translated into their equivalent ISBN number format.

MSI

Click the "MSI" in the left list then all its related parameters will be shown on the right.

Minimum Length: output the decode result when the symbology length equal or larger than the minimum length.

Maximum Length: output the decode result when the symbology length equal or shorter than the maximum length.

Check Character: Different types of check characters are used with MSI bar codes. You can program the HF800 to read MSI bar codes with Type 10 check characters. When Check Character is set to **Validate Type 10/11 and Transmit**, the HF800 only reads MSI bar codes printed with the specified type check character(s), and transmits the character(s) at the end of the scanned data. When Check Character is set to **Validate Type 10/11, but Don't Transmit**, the unit only reads MSI bar codes printed with the specified type check character(s), but does not transmit the check character(s) with the scanned data.

GS1 DataBar Omnidirectional

Click the "GS1 DataBar Omnidirectional" in the left list then all its related parameters will be shown on the right.

GS1 Databar Omnidirectional

Minimum Length (0~80)	4
Maximum Length (0~90)	74

Minimum Length: output the decode result when the symbology length equal or larger than the minimum length.

Maximum Length: output the decode result when the symbology length equal or shorter than the maximum length.

GS1 DataBar Limited

Click the “GS1 DataBar Limited” in the left list then all its related parameters will be shown on the right.

GS1 Databar Limited

Minimum Length (0~80)	4
Maximum Length (0~90)	74

Minimum Length: output the decode result when the symbology length equal or larger than the minimum length.

Maximum Length: output the decode result when the symbology length equal or shorter than the maximum length.

GS1 DataBar Expanded

Click the “GS1 DataBar Expanded” in the left list then all its related parameters will be shown on the right.

GS1 Databar Expanded

Minimum Length (0~80)	4
Maximum Length (0~90)	74

Minimum Length: output the decode result when the symbology length equal or larger than the minimum length.

Maximum Length: output the decode result when the symbology length equal or shorter than the maximum length.

Stacked Symbologies

Enable/Disable all Stacked symbologies

Open DataMax[®] Configuration Program and connect the device first.
Go to the tab page “Symbologies” and click the “Stacked Linear” sub page.
Check the check box “Check All” will enable all the Stacked symbologies present in the list.
Uncheck it will disable all the Stacked symbologies present in the list.

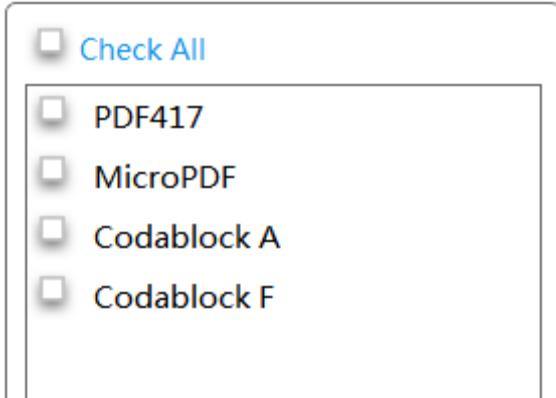

PDF417

Click the “PDF417” in the left list then all its related parameters will be shown on the right.

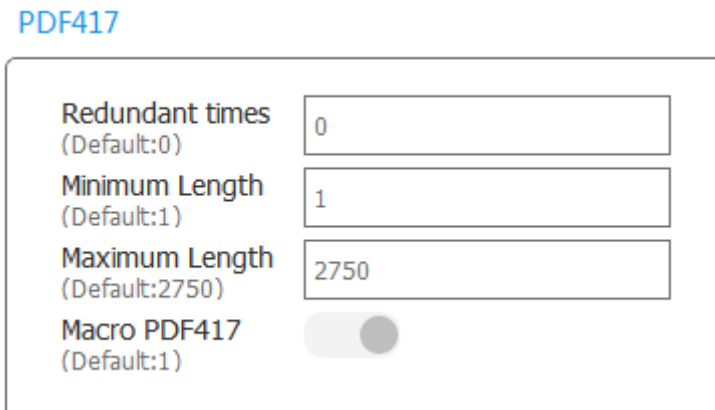

Redundant times: output the decode result only when got identical barcodes information for specific times.
Minimum Length: output the decode result when the symbology length equal or larger than the minimum length.
Maximum Length: output the decode result when the symbology length equal or shorter than the maximum length.
Macro PDF417: MacroPDF417 is an implementation of PDF417 capable of encoding very large amounts of data into multiple PDF417 bar codes. When this selection is enabled, these multiple bar codes are assembled into a single data string.

MicroPDF

Click the "MicroPDF" in the left list then all its related parameters will be shown on the right.

MicroPDF

Redundant times (Default:0)	<input type="text" value="0"/>
Minimum Length (Default:1)	<input type="text" value="1"/>
Maximum Length (Default:366)	<input type="text" value="366"/>

Redundant times: output the decode result only when got identical barcodes information for specific times.

Minimum Length: output the decode result when the symbology length equal or larger than the minimum length.

Maximum Length: output the decode result when the symbology length equal or shorter than the maximum length.

Codablock A

Click the "Codablock A" in the left list then all its related parameters will be shown on the right.

Codablock A

Redundant times (Default:0)	<input type="text" value="0"/>
Minimum Length (Default:1)	<input type="text" value="1"/>
Maximum Length (Default:600)	<input type="text" value="600"/>

Redundant times: output the decode result only when got identical barcodes information for specific times.

Minimum Length: output the decode result when the symbology length equal or larger than the minimum length.

Maximum Length: output the decode result when the symbology length equal or shorter than the maximum length.

Codablock F

Click the "Codablock F" in the left list then all its related parameters will be shown on the right.

Codablock F

Redundant times (Default:0)	<input type="text" value="0"/>
Minimum Length (Default:1)	<input type="text" value="1"/>
Maximum Length (Default:2048)	<input type="text" value="2048"/>

Redundant times: output the decode result only when got identical barcodes information for specific times.

Minimum Length: output the decode result when the symbology length equal or larger than the minimum length.

Maximum Length: output the decode result when the symbology length equal or shorter than the maximum length.

2-D Symbologies

Enable/Disable all 2-D symbologies

Open DataMax[®] Configuration Program and connect the device first.

Go to the tab page “Symbologies” and click the “2D” sub page.

Check the check box “Check All” will enable all the 2-D symbologies present in the list.

Uncheck it will disable all the 2-D symbologies present in the list.

Aztec

Click the “Aztec” in the left list then all its related parameters will be shown on the right.

Aztec

Redundant times (Default:0)	<input type="text" value="0"/>
Minimum Length (Default:1)	<input type="text" value="1"/>
Maximum Length (Default:3832)	<input type="text" value="3832"/>
Append Mode (Default:1)	<input type="checkbox"/>
Strip Append Information (Default:1)	<input type="checkbox"/>

Redundant times: output the decode result only when got identical barcodes information for specific times.

Minimum Length: output the decode result when the symbology length equal or larger than the minimum length.

Maximum Length: output the decode result when the symbology length equal or shorter than the maximum length.

Append Mode: This function allows the HF800 to append the data from several HF800 bar codes together before transmitting them to the host computer. When the HF800 encounters an Aztec bar code with the append trigger character(s), it buffers the number of Aztec bar codes determined by information encoded in those bar codes. Once the proper number of codes is reached, the data is output in the order specified in the bar codes.

Strip Append Information: When enabled strips off the append information from the barcode. Details of what that info is can be found in the Aztec ISO specification. For debug purposes, this mode allows the append information to be output with the data.

Maxicode

Click the “Maxicode” in the left list then all its related parameters will be shown on the right.

Maxicode

Redundant times (Default:0)	<input type="text" value="0"/>
Minimum Length (Default:1)	<input type="text" value="1"/>
Maximum Length (Default:150)	<input type="text" value="150"/>

Redundant times: output the decode result only when got identical barcodes information for specific times.

Minimum Length: output the decode result when the symbology length equal or larger than the minimum length.

Maximum Length: output the decode result when the symbology length equal or shorter than the maximum length.

QR Code

Click the “QR Code” in the left list then all its related parameters will be shown on the right.

QRCode

Redundant times (Default:0)	<input type="text" value="0"/>
Minimum Length (Default:1)	<input type="text" value="1"/>
Maximum Length (Default:7089)	<input type="text" value="7089"/>
Append Mode (Default:1)	<input checked="" type="checkbox"/>

Redundant times: output the decode result only when got identical barcodes information for specific times.

Minimum Length: output the decode result when the symbology length equal or larger than the minimum length.

Maximum Length: output the decode result when the symbology length equal or shorter than the maximum length.

Append Mode: This function allows the HF800 to append the data from several QR HF800 bar codes together before transmitting them to the host computer. When the HF800 encounters an QR Code bar code with the append trigger character(s), it buffers the number of QR Code bar codes determined by information encoded in those bar codes. Once the proper number of codes is reached, the data is output in the order specified in the bar codes.

DataMatrix

Click the “DataMatrix” in the left list then all its related parameters will be shown on the right.

DataMatrix

Redundant times (Default:0)	<input type="text" value="0"/>
Minimum Length (Default:1)	<input type="text" value="1"/>
Maximum Length (Default:3116)	<input type="text" value="3116"/>

Redundant times: output the decode result only when got identical barcodes information for specific times.

Minimum Length: output the decode result when the symbology length equal or larger than the minimum length.

Maximum Length: output the decode result when the symbology length equal or shorter than the maximum length.

HanXin

Click the “HanXin” in the left list then all its related parameters will be shown on the right.

HanXin

Redundant times (Default:0)	<input type="text" value="0"/>
Minimum Length (Default:1)	<input type="text" value="1"/>
Maximum Length (Default:7833)	<input type="text" value="7833"/>

Redundant times: output the decode result only when got identical barcodes information for specific times.

Minimum Length: output the decode result when the symbology length equal or larger than the minimum length.

Maximum Length: output the decode result when the symbology length equal or shorter than the maximum length.

Decoder Configurations

This chapter will list most of the decoding related parameters to configure the activity of the reader. The “Decoding” Tab page inside the DataMax[®] Configuration Program includes all the related configurations.

General Settings

Reread Delay

This is an important parameter in this mode which sets the time period before the reader can read the same barcode a second time. Setting a reread delay protects against accidental rereads the same barcode. Longer delays are effective in minimizing accidental rereads. Use shorter delays in applications where repetitive barcode scanning is required.

Go to the “Decoding” Tab page and input the desired delay value into the edit box “Re-read Delay (ms)”. *Default = 750ms.*

This setting will take effect on “Streaming Presentation Mode” and “Presentation Mode”.

Information	Tuning	Symbologies	Operation Mode	Decoding
Re-read Delay(ms) (0~30000)	750			Read (0~30000)
Good Read Delay(ms) (0~30000)	0			Enab
Decode Timeout(ms) (0~2400)	155			Show

Read TimeOut

Use this selection to set a time-out (in milliseconds) of the reader’s trigger when using external signal or commands to trigger the reader.

Once the reader has timed out, you can activate the reader either by re-start external signal or using the trigger command.

This parameter can only work in External Trigger mode or Self-Trigger mode.

Read Timeout(ms) (0~300000)	2000
--------------------------------	------

Good Read Delay

This sets the minimum amount of the time before the reader can read another bar code.

This parameter can only work in External Trigger mode or Self-Trigger mode.

Good Read Delay(ms)
(0~30000)

Decode Timeout

This sets the maximum time duration that the reader used to decode each image.

Decode Timeout(ms)
(0~2400)

DPM Support

This setting can enable or disable the support of DPM code.

Enable DPM



Show No Read

When enable this setting, if the reader failed to decode, it will output a string “NR” to notify the user.

This parameter can only work in External Trigger mode or Self-Trigger mode.

Show No Read



Output Sequence

Output Sequence Overview

This programming selection allows you to program the reader to output data (when scanning more than one symbol) in whatever order your application requires, regardless of the order in which the bar codes are scanned.

To apply for the output sequence matching, user can edit the matching rule before execute it. The reader can support to add the following items into the matching sequence.

1, Code ID

This can designate the specific symbology type which we want to apply the output sequence format.

2, Length

Specify what length (up to 9999 characters) of data output will be acceptable for this symbology. 9999 is an universal number, indicating all lengths.

When calculating the length, you must count any programmed prefixes, suffixes, or formatted characters as part of the length (unless using 9999).

3, Character Match Sequences

Specify the first character(s) you want to match.

99 is the Universal number, indicating all characters.

In the “Decoding” tab page, click the button  can add one item.

Click the button  can remove one item from the list.

Code Items Add Code Active

ID	Code Type	Length	Head String		
1	Code 39	12	A	Delete	Down
2	Code 128	13	B	Delete Up	Down
3	Code 93	12	C	Delete Up	

We can also adjust the items order by click the button  and .

After all the items were done, click the button  will configure the edited output sequence into the reader.

And this sequence will take effect immediately.

Output Sequence Configuration Panel

To enable the output sequence matching, we should also configure some following settings.

Output Mode	<input type="text" value="Off"/>	Separator	<input type="text"/>
Transmit Partial Sequence	<input type="checkbox"/>	Partial Prefix	<input type="text"/>
Partial Suffix	<input type="text"/>	Code Sequence	<input type="text" value="Random"/>
Total Timeout (0-9999)	<input type="text" value="0"/>		

Output Mode

When the output sequence is **Off**, the bar code data is output to the host as the reader decodes it.

When an output sequence is **Required**, all output data must conform to an edited sequence or the reader will not transmit the output data to the host device.

When it's **On/Not Required**, the reader will attempt to get output data to conform to an edited sequence but, if it cannot, the reader transmits all output data to the host device as is.

When it's **No Rule**, the output data will not conform to the edited sequence, it will buffer all the decoded data and output them when the timeout occurs or the data numbers meet the scan count. The scan count can also be set.

Transmit Partial Sequence

If an output sequence operation is terminated before all your output sequence criteria are met, the bar code data acquired to that point is a "partial sequence".

Disable this function will discard partial sequences when the output sequence operation is terminated before completion.

Enable this function will transmit the partial sequences. (Any fields in the sequence where no data match occurred will be skipped in the output.)

Partial Prefix

This setting is to add prefix to partial output sequences.

Partial Suffix

This setting is to add suffix to partial output sequences.

Separator

This setting is to add separators to the output sequences.

Code Sequence

This setting is to control the output ordering rule when output the sequence.

Random:

Barcode result will output randomly.

Top-Bottom:

Barcode result will output from top to bottom according to their coordination in the image.

Left-Right:

Barcode result will output from left to right according to their coordination in the image.

Total Timeout

Timeout for reading the total configured sequence. When the timer expires, the current reading process will stop.

Input/output settings

Input Channel settings

There are two inputs on the reader, with the protection of 2 polarity insensitive optocouplers: input1 and input2, they work with same functions as external trigger. Its main functions are: acquisition trigger in external trigger mode. By default, input1 and input2 are associated with None polarity, the input signals are fully programmable by the users.

Polarity and Debounce time

Select **I/O** tab of the DataMax[®].

	1	2
Input		
Polarity	NONE	NONE
Debounce Time(ms)	2	2
Output		
Message/Event	Off	Off
Duration Time(ms)	100	100
Output Delay Time(ms)	100	100

1. **Polarity** The active state of these inputs is: **NONE, Rising Edge, Falling Edge, Low Level, High Level.**
2. **Debounce time** an anti-disturbance filter. The value can be changed through the software parameter;

To set input1 or input2 work as external trigger, the Operation Mode should be set to external Trigger mode, there are **one shot mode, burst mode, continuous mode** under external trigger mode.

For example:

If select Polarity Low Level. Set the Operation Mode to **Continuous mode**, the low level will start decoding barcode and the High level will stop decoding. If the Reader get the barcode data during the low level, it will also stop decoding.

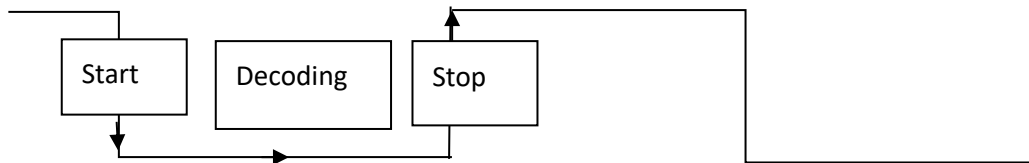

If select Falling edge, set the Operation Mode to **Continuous mode**, the Falling signal will start decoding barcode, it will stop until read time out or get the right barcode data.

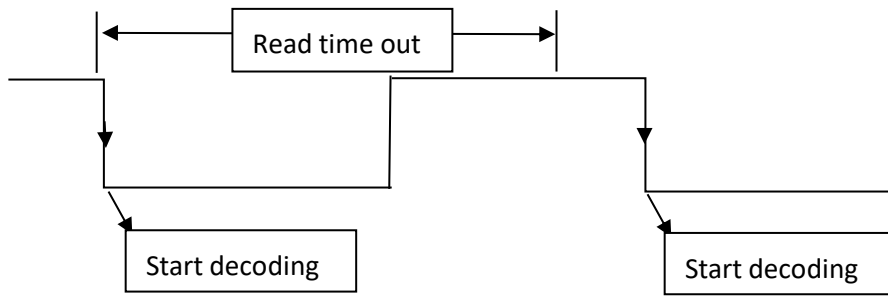

Output Channel settings

Two general purpose outputs are available, with the protection of 2 optocouplers. The meaning of the two outputs Output 1 and Output 2 can be defined by the user. They are typically used either to signal the data collection result or to control an external lighting system.

The following settings are about Output1 and Output2:

Output	1	2
Message/Event	Good Read	Good Read
Duration Time(ms)	100	100
Output Delay Time(ms)	100	100

Message/Event: By default, Output signals are associated with the **OFF event**, which are fully programmable being determined by the configured **Good Read event**, **No Read event**, **Error Read event**.

No Read event which activates when the code(s) signaled by the external trigger are not decoded.

Good Read event, which activates when all the selected codes are correctly decoded.

For example:

If we configure output 1 with Good read event, Duration Time 100ms, output delay time 100ms.

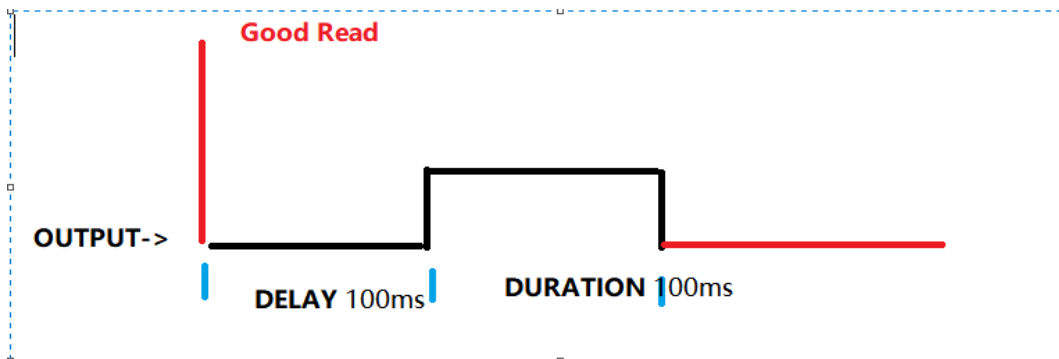

Data Editing and Formatting

Prefix/Suffix Overview

When a bar code is scanned, additional information is sent to the host computer along with the barcode data. This group of bar code data and additional, user-defined data is called a “message string”. The selections in this section are used to build the user-defined data into the message string.

Prefix and Suffix characters are data characters that can be sent before and after scanned data. The data characters can be sent with all symbologies, or only with specific symbologies.

Prefix	Scanned Data	Suffix
---------------	---------------------	---------------

Prefix/Suffix Selections

Select tab “Data”.

Information Tuning Symbologies Operation Mode Decoding Interface I/O **Data** Debug

Symbologies All Symbologies Add

Settings

Prefix

Suffix

Data

Full Code String Add Active

Advance Mode(Use Command Line)

A prefix or suffix may be added or cleared from one symbology or all symbologies.

Select Symbologies from the lists and click button

Add

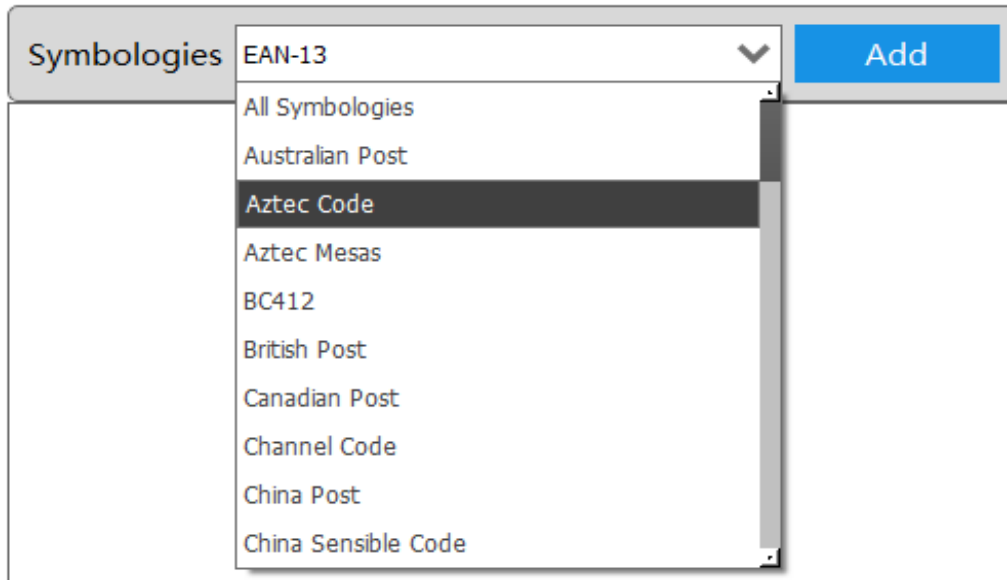

Enter character in the setting prefixes/suffixes chart box to appear on the output.
Default prefix is empty.
Default suffix is empty.

Settings

Prefix

Surfix

For example:

1. Select all symbologies

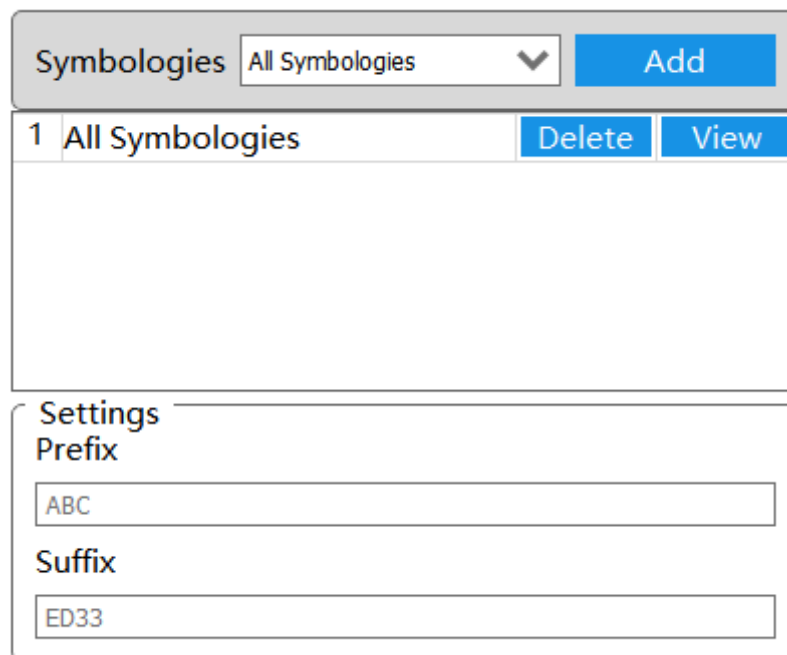

2. Use the follow barcode, the data is output as:

ABC1234567890ABCDEFGHIJED33



3. Clear prefix and suffix

Just delete prefix: **ABC** or suffix: **ED33**

Data Format Editor Introduction

To use the Data Format Editor to change the device’s output. For example, to insert characters at certain points in barcode data as it is scanned. The selections in the following pages are used only if you wish to alter the output. Default Data Format is output original data content.

The maximum size of a data format configuration is 2000 bytes, which includes header information.

Add a Data Format

Step 1. Select **Data** tab.

Step 2. Select the symbology from the symbologies list and click the **View** button to select the detail setting.

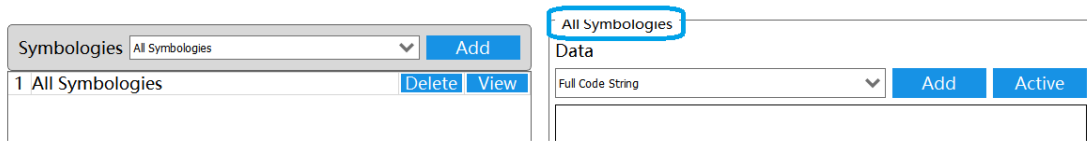

Step 3. There are 4 data format that you can chose.

Notes: When working with the Data Format Editor, a virtual cursor is moved along your input data string. The following commands are used to both move this cursor to different positions, and to select, replace, and insert data into the final output.

Full Code String Include in the output message all of the characters from the input message, starting from current cursor position, followed by an insert character.

Sub Code String Include in the output message a number of characters followed by an insert character. Start from the “Start position” which user input and continue for “Length” characters or through “Drop Last Length” the character in the input message.

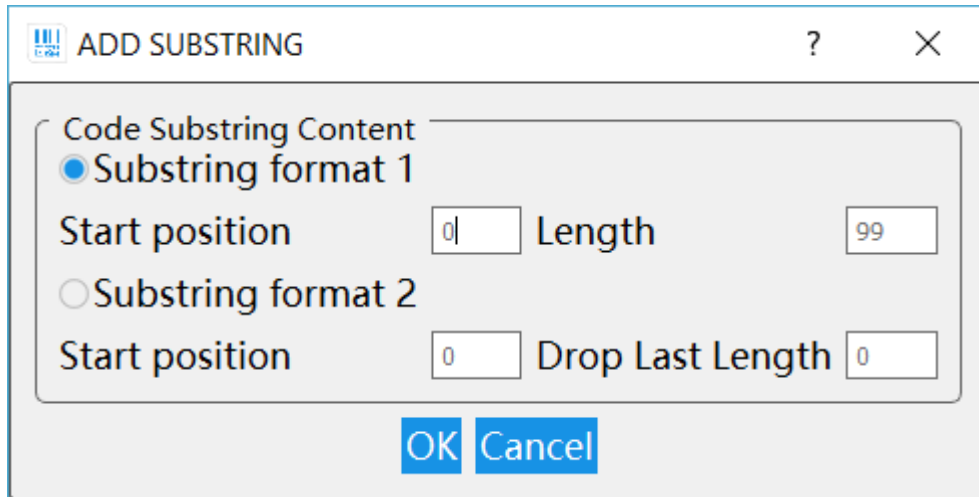

Code Type Name Insert the name of the bar code's symbology in the output message, without moving the cursor. Only symbologies with a Honeywell ID are included

Code Length Insert the bar code's length in the output message, without moving the cursor. The length is expressed as a numeric string and does not include leading zeroes.

For example:

1. Add data format

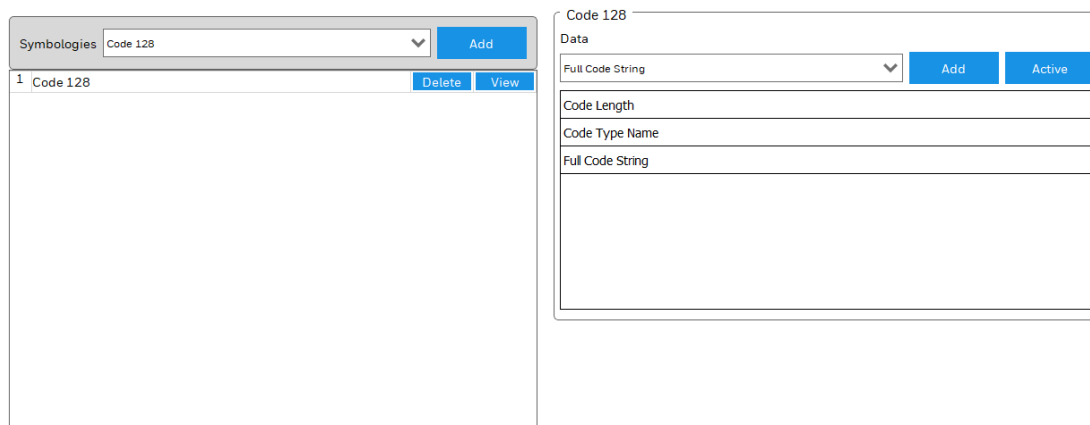

2. Click **Active**

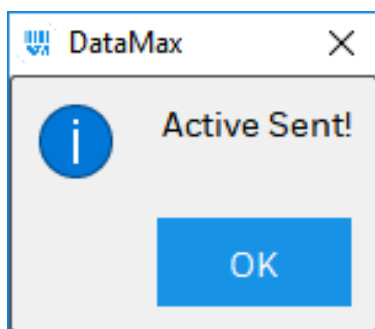

3. Use the follow barcode, the data is output as:
20Code1281234567890ABCDEFGHIJ



4. Clear data format

Chose the format you want to delete, then click **Active**

Code Length	
Code Type Name	
Full Code String	Delete

Advance Mode (command Line)

To use advance mode:

- Advance Mode(Use Command Line)

DFMBK3

Advance mode is to edit data format by command line, by using command line, more data format can be used more flexibly

Maintenance

Firmware upgrade

DataMax[®] allows user to upgrade the reader's firmware.

1. Click the Update Firmware tab.

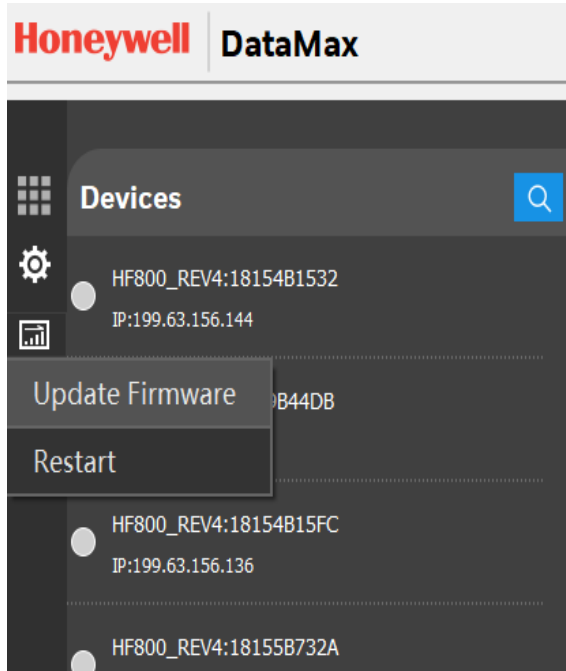

2. Click "choose file" and select the ". SMOC" file.

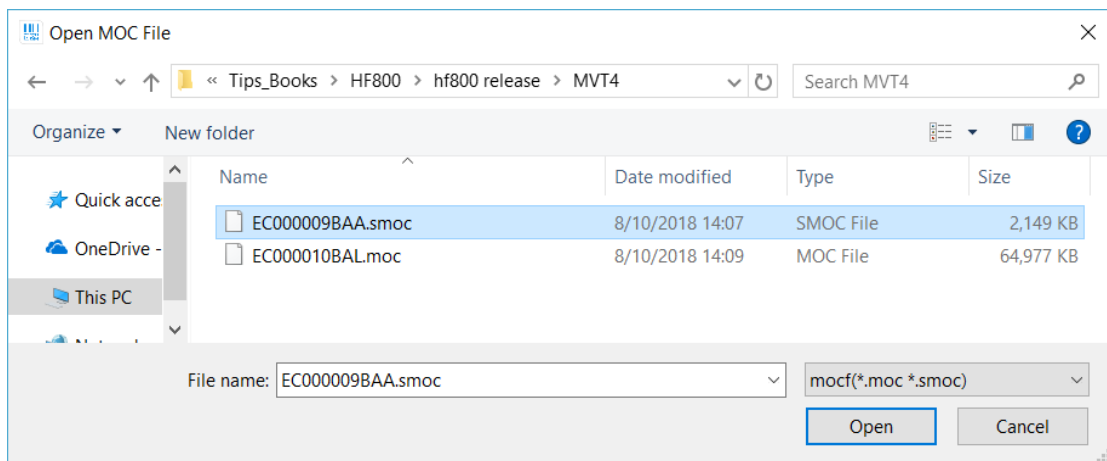

3. Click "open" and wait it done. The device will restart automatically after the file transfer is completed. Please do not turn off device power, during the upgrade.

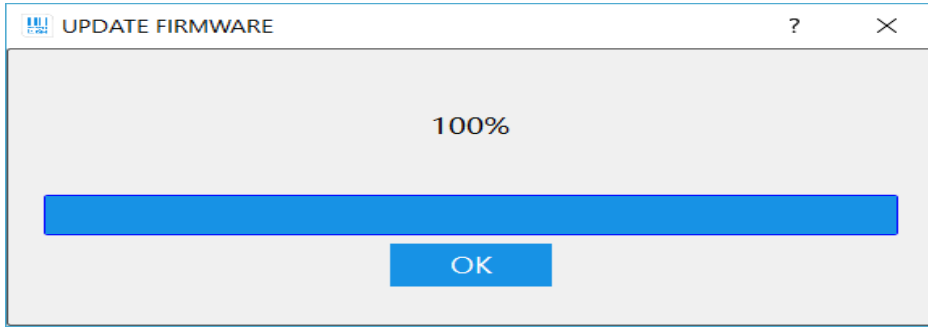

Trouble Shooting

Problems	Suggestion
DataMax [®] installation	<p>Check the following points, and then install the software again.</p> <ul style="list-style-type: none"> • Administrator rights To install the software, log on as a user with Administrator rights. • Security software The installation may be impeded by security software. Temporarily disable the security software.
DataMax [®] running	<p>When first time runs DataMax[®] after installed, it may be blocked by firewall and the system may ask you to confirm DataMax[®] to access network, be sure to click all allow option.</p>
Power ON but the "POWER" LED is not lit.	<p>Is power connected? If using a power adapter, please make sure use the Honeywell recommend power adaptor. If using customer power, please make sure the proper wired with Vin and GND on the connector. See detail information as on page 11</p>
Unable to connect to DataMax [®]	<p>Check the following points,</p> <ul style="list-style-type: none"> • RS232/485 connection (page 19) • Ethernet connection (page 18) <p>Make sure the units are properly configured to the related working mode.</p>
Device is not displayed in the Device Selection Area	<p>To be found by DataMax[®], Online devices must be powered on and connected to the Local Area Network; if you don't see the desired device within this list, please verify its connections to the LAN and assure it is powered on; then click on the Search icon  to run a new device search.</p>

	If device is connected via serial port, be sure to select correct parameters (Data Bits/Stop Bits/Parity).
Reading failure	<ul style="list-style-type: none"> - Tune the Acquisition Delay on Trigger, if the moving code is out of the reader field of view; - Set the streaming presentation/presentation Operating Mode if no external trigger source is available; - Fine tune the Image Setup to improve the code image quality; - Check the code parameter settings in the Symbology Setup step: 2D , Linear, and Stacked Linear; - View the full resolution code image to check the printing or marking quality.
Unable to trigger the device with external trigger source or soft trigger	Is the external sensor wiring correct? Check the I/O input according to external sensor parameter.
Communication: device is not transmitting anything to the host.	<p>Make sure the wire is properly connected.</p> <p>Make sure the configuration is related to the actual working mode.</p> <p>Are the host serial port settings the same as the reader serial port settings?</p>
Communication: data transferred to the host are incorrect.	In the DataMax [®] , Data Formatting step check the settings of Prefix and Suffix String and other parameters.

Customer Support

Technical Assistance

If you need assistance installing or troubleshooting your device, please contact us by using one of the methods below:

Knowledge Base: www.hsmknowledgebase.com

Our Knowledge Base provides thousands of immediate solutions. If the Knowledge Base cannot help, our Technical Support Portal(see below) provides an easy way to report your problem or ask your question.

Technical Support Portal: www.hsmsupportportal.com

The Technical Support Portal not only allows you to report your problem, but it also provides immediate solutions to your technical issues by searching our Knowledge Base. With the Portal, you can submit and track your questions online and send and receive attachments.

Web form: www.hsmcontactsupport.com

You can contact our technical support team directly by filling out our online support form. Enter your contact details and the description of the question/problem.

Telephone: www.honeywellaidc.com/locations

For our latest contact information, please check our website at the link above.

Product Service and Repair

Honeywell International Inc. Provides service for all of its products through service centers throughout the world. To obtain warranty or non-warranty service, please visit www.honeywellaidc.com and select **Support > Contact Service** and Repair to see your region's instructions on how to obtain a Return Material Authorization number(RMA #).You should do this prior to returning the product.

Limited Warranty

Honeywell International Inc. ("HII") warrants its products to be free from defects in materials and workmanship and to conform to HII's published specifications applicable to the products purchased at the time of shipment. This warranty does not cover any HII product which is (i) improperly installed or used; (ii) damaged by accident or negligence, including failure to follow the proper maintenance, service, and cleaning schedule; or (iii) damaged as a result of (A) modification or alteration by the purchaser or other party, (B) excessive voltage or current supplied to or drawn from the interface connections, (C) static electricity or electro-static discharge, (D) operation under conditions beyond the specified operating parameters, or (E) repair or service of the product by anyone other than HII or its authorized representatives. This warranty shall extend from the time of shipment for the duration published by HII for the product at the time of purchase ("Warranty Period"). Any defective product must be returned (at purchaser's expense) during the Warranty Period to HII factory or authorized service center for inspection. No product will be accepted by HII without a Return Materials Authorization, which may be obtained by contacting HII. In the event that the product is returned to HII or its authorized service center within the Warranty Period and HII determines to its satisfaction that the product is defective due to defects in materials or workmanship, HII, at its sole option, will either repair or replace the product without charge, except for return shipping to HII.

EXCEPT AS MAY BE OTHERWISE PROVIDED BY APPLICABLE LAW, THE FOREGOING WARRANTY IS IN LIEU OF ALL OTHER COVENANTS OR WARRANTIES, EITHER EXPRESSED OR IMPLIED, ORAL OR WRITTEN, INCLUDING, WITHOUT LIMITATION, ANY IMPLIED WARRANTIES OF MERCHANTABILITY OR FITNESS FOR A PARTICULAR PURPOSE, OR NON-INFRINGEMENT.

HII'S RESPONSIBILITY AND PURCHASER'S EXCLUSIVE REMEDY UNDER THIS WARRANTY IS LIMITED TO THE REPAIR OR REPLACEMENT OF THE DEFECTIVE PRODUCT WITH NEW OR REFURBISHED PARTS. IN NO EVENT SHALL HII BE LIABLE FOR INDIRECT, INCIDENTAL, OR CONSEQUENTIAL DAMAGES, AND, IN NO EVENT, SHALL ANY LIABILITY OF HII ARISING IN CONNECTION WITH ANY PRODUCT SOLD HEREUNDER (WHETHER SUCH LIABILITY ARISES FROM A CLAIM BASED ON CONTRACT, WARRANTY, TORT, OR OTHERWISE) EXCEED THE ACTUAL AMOUNT PAID TO HII FOR THE PRODUCT. THESE LIMITATIONS ON LIABILITY SHALL REMAIN IN FULL FORCE AND EFFECT EVEN WHEN HII MAY HAVE BEEN ADVISED OF THE POSSIBILITY OF SUCH INJURIES, LOSSES, OR DAMAGES. SOME STATES, PROVINCES, OR COUNTRIES DO NOT ALLOW THE EXCLUSION OR LIMITATIONS OF INCIDENTAL OR CONSEQUENTIAL DAMAGES, SO THE ABOVE LIMITATION OR EXCLUSION MAY NOT APPLY TO YOU.

All provisions of this Limited Warranty are separate and severable, which means that if any provision is held invalid and unenforceable, such determination shall not affect the validity or enforceability of the other provisions hereof. Use of any peripherals not provided by the manufacturer may result in damage not covered by this warranty. This includes but is not limited to: cables, power supplies. HII extends these warranties only to the first end-users of the products. These warranties are non-transferable.

The duration of the limited warranty for the HF800 reader is ninety (3) years.

Appendix A

Enable Network DHCP, function will take effect after restart the device.



Disable Network DHCP, function will take effect after restart the device.



Reboot the reader

